



FINAL PROJECT

“Design a four-cylinder Internal Combustion Engine”

Project and Engineering Department

Student: Radoslav Plamenov Georgiev

Tutors: Dr. Pedro Villanueva Roldan Dk.

Pamplona, 27.06.2011

Contents

1. Introduction.....	4
2. Goals and Objectives	5
3. History and Development of engine	6
3.1. The Importance of Nicolaus Otto	7
3.2. The Importance of Karl Benz	8
3.3. The Importance of Gottlieb Daimler	9
3.4. The Importance of Henry Ford (1863-1947)	11
3.5. The Importance of Rudolf Diesel.....	12
4. Types of engines.....	14
4.1. In Line	14
4.2. Horizontally opposed	17
4.3. Radial Engine	19
4.4. V engine.....	20
5. Main components of the engine	22
5.1. Piston.....	22
5.2. Piston Rings	24
5.3. Connecting Rod	26
5.4. Crankshaft	27
5.5. Camshaft.....	28
6. Kinematics Calculation of a supercharging engine.....	30
7. Dynamic Calculation of an engine with supercharging	37
7.1. Gas Forces	37
7.2. Inertia Forces.....	38
7.3. Forces acting on the crank-connection rod mechanism	39
7.4. Connection Rod bearings	40
7.5. Equilibration of the engine.....	41
7.6. Flywheel.....	42
8. Calculation of the engine block and crankcase	44
8.1. Cylinders	44
8.2. Cylinder Head	45
8.3. Strength Stud bolts.....	46
9. Calculation of piston group	48
9.1. Piston.....	48

9.1.1.	Tension pressure	50
9.1.2.	Tension stress of the area x-x.....	52
9.2.	Piston Pin.....	54
9.3.	Piston rings	59
9.3.1.	Determination of the average radial pressure on the cylinder walls caused by the ring 60	
9.3.2.	Determination of bending stress in the piston rings.....	61
10.	Calculation of the connecting rod	63
10.1.	Upper head of the connecting rod	65
10.2.	Stem of the connecting rod.....	67
10.3.	Lower head of the connecting rod	70
10.4.	Connecting rod pins.....	72
11.	Calculation of the crankshaft mechanism	73
11.1.	Dimensions	73
11.2.	Calculation of full-supporting crankshaft	74
11.3.	Calculation of the journals.....	76
12.	Used Materials	78
13.	Conclusion	79
14.	References.....	81
15.	Drawings.....	82
16.	Drawings 3D	83

1. Introduction

We almost take our Internal Combustion Engines for granted don't we? All we do is buy our vehicles, hop in and drive around. There is, however, a history of development to know about. The compact, well-toned, powerful and surprisingly quiet engine that seems to be purr under your vehicle's hood just wasn't the tame beast it seems to be now. It was loud, it used to roar and it used to be rather bulky. In fact, one of the very first engines that had been conceived wasn't even like the engine we know so well of today.

An internal combustion engine is defined as an engine in which the chemical energy of the fuel is released inside the engine and used directly for mechanical work, as opposed to an external combustion engine in which a separate combustor is used to burn the fuel.

The internal combustion engine was conceived and developed in the late 1800s. It has had a significant impact on society, and is considered one of the most significant inventions of the last century. The internal combustion engine has been the foundation for the successful development of many commercial technologies. For example, consider how this type of engine has transformed the transportation industry, allowing the invention and improvement of automobiles, trucks, airplanes and trains.

Internal combustion engines can deliver power in the range from 0.01 kW to 20×10^3 kW, depending on their displacement. The complete in the market place with electric motors, gas turbines and steam engines. The major applications are in the vehicle (automobile and truck), railroad, marine, aircraft, home use and stationary areas. The vast majority of internal combustion engines are produced for vehicular applications, requiring a power output on the order of 10^2 kW.

Next to that internal combustion engines have become the dominant prime mover technology in several areas. For example, in 1900 most automobiles were steam or electrically powered, but by 1900 most automobiles were powered by gasoline engines. As of year 2000, in the United States alone there are about 200 million motor vehicles powered by internal combustion engines. In 1900, steam engine were used to power ships and railroad locomotives; today two- and four-stroke diesel

engine are used. Prior to 1950, aircraft relied almost exclusively on the pistons engines. Today gas turbines are the power plant used in large planes, and piston engines continue to dominate the market in small planes. The adoption and continued use of the internal combustion engine in different application areas has resulted from its relatively low cost, favorable power to weight ratio, high efficiency, and relatively simple and robust operating characteristics.

The components of a reciprocating internal combustion engine, block, piston, valves, crankshaft and connecting rod have remained basically unchanged since the late 1800s. The main differences between a modern day engine and one built 100 years ago are the thermal efficiency and the emission level. For many years, internal combustion engine research was aimed at improving thermal efficiency and reducing noise and vibration. As a consequence, the thermal efficiency has increased from about 10% to values as high as 50%. Since 1970, with recognition of the importance of air quality, there has also been a great deal of work devoted to reducing emissions from engines. Currently, emission control requirements are one of the major factors in the design and operation of internal combustion engines.

2. Goals and Objectives

The aim of this Thesis is to introduce to the interesting world of internal combustion engines and to describe what actually Internal Combustion Engine is. What are its main components and structure. How the engine indeed operates. Also to design a real engine, having into account all necessary calculations concerning with kinematics, dynamics and strength calculation of basic details. Another purpose of the project is to define the proper materials for each part. Next to that I will make 2D and 3D drawings on CATIA and animation of working Internal Combustion Engine.

3. History and Development of engine

A brief outline of the history of the internal combustion engine includes the following highlights:

- **1680** - Dutch physicist, Christian Huygens designed (but never built) an internal combustion engine that was to be fueled with gunpowder.
- **1807** - Francois Isaac de Rivaz of Switzerland invented an internal combustion engine that used a mixture of hydrogen and oxygen for fuel. Rivaz designed a car for his engine - the first internal combustion powered automobile. However, his was a very unsuccessful design.
- **1824** - English engineer, Samuel Brown adapted an old Newcomen steam engine to burn gas, and he used it to briefly power a vehicle up Shooter's Hill in London.
- **1858** - Belgian-born engineer, Jean Joseph Étienne Lenoir invented and patented (1860) a double-acting, electric spark-ignition internal combustion engine fueled by coal gas. In 1863, Lenoir attached an improved engine (using petroleum and a primitive carburetor) to a three-wheeled wagon that managed to complete an historic fifty-mile road trip
- **1862** - Alphonse Beau de Rochas, a French civil engineer, patented but did not build a four-stroke engine (French patent #52,593, January 16, 1862).
- **1864** - Austrian engineer, Siegfried Marcus, built a one-cylinder engine with a crude carburetor, and attached his engine to a cart for a rocky 500-foot drive. Several years later, Marcus designed a vehicle that briefly ran at 10 mph that a few historians have considered as the forerunner of the modern automobile by being the world's first gasoline-powered vehicle
- **1873** - George Brayton, an American engineer, developed an unsuccessful two-stroke kerosene engine (it used two external pumping cylinders). However, it was considered the first safe and practical oil engine.
- **1866** - German engineers, Eugen Langen and Nikolaus August Otto improved on Lenoir's and de Rochas' designs and invented a more efficient gas engine.
- **1876** - Nikolaus August Otto invented and later patented a successful four-stroke engine, known as the "Otto cycle".

- **1876** - The first successful two-stroke engine was invented by Sir Dougald Clerk.
- **1883** - French engineer, Edouard Delamare-Debouteville, built a single-cylinder four-stroke engine that ran on stove gas. It is not certain if he did indeed build a car, however, Delamare-Debouteville's designs were very advanced for the time - ahead of both Daimler and Benz in some ways at least on paper.
- **1885** - Gottlieb Daimler invented what is often recognized as the prototype of the modern gas engine - with a vertical cylinder, and with gasoline injected through a carburetor (patented in 1887). Daimler first built a two-wheeled vehicle the "Reitwagen" (Riding Carriage) with this engine and a year later built the world's first four-wheeled motor vehicle.
- **1886** - On January 29, Karl Benz received the first patent (DRP No. 37435) for a gas-fueled car.
- **1889** - Daimler built an improved four-stroke engine with mushroom-shaped valves and two V-slant cylinders.
- **1890** - Wilhelm Maybach built the first four-cylinder, four-stroke engine.

3.1. The Importance of Nicolaus Otto

One of the most important landmarks in engine design comes from Nicolaus August Otto who in 1876 invented an effective gas motor



engine. Otto built the first practical four-stroke internal combustion engine called the "Otto Cycle Engine," and as soon as he had completed his engine, he built it into a motorcycle. Otto's contributions were very historically significant, it was his four-stroke engine that was universally adopted for all liquid-fueled automobiles going forward. Nicolaus Otto was born on June 14, 1832 in Holzhausen, Germany. Otto's first occupation was as a traveling salesman selling tea, coffee, and sugar. He soon developed an interest in the new technologies of the day and began experimenting with building four-stroke engines (inspired by Lenoir's two-stroke gas-driven internal combustion engine). After meeting Eugen Langen, a technician and owner of a sugar factory, Otto quit his job,

and in 1864, the duo started the world's first engine manufacturing company N.A. Otto & Cie (now DEUTZ AG, Köln). In 1867, the pair were awarded a Gold Medal at the Paris World Exhibition for their atmospheric gas engine built a year earlier.

In May 1876, Nicolaus Otto built the first practical four-stroke piston cycle internal combustion engine. He continued to develop his four-stroke engine after 1876 and he considered his work finished after his invention of the first magneto ignition system for low voltage ignition in 1884. Otto's patent was overturned in 1886 in favor of the patent granted to Alphonse Beau de Roaches for his four-stroke engine. However, Otto built a working engine while Roaches' design stayed on paper. On October 23, 1877, another patent for a gas-motor engine was issued to Nicolaus Otto, and Francis and William Crossley.

3.2. The Importance of Karl Benz

In 1885, German mechanical engineer, Karl Benz designed and built the world's first practical automobile to be powered by an internal-combustion engine. On January 29, 1886, Benz received the first patent (DRP No. 37435) for a gas-fueled car. It was a three-wheeler; Benz built his first four-wheeled car in 1891. Benz & Cie., the company started by the inventor, became the world's largest manufacturer of automobiles by 1900. Benz was the first inventor to integrate an internal combustion engine with a chassis - designing both together.



Karl Friedrich Benz was born in 1844 in Baden Muehlburg, Germany (now part of Karlsruhe). He was the son of an engine driver. Benz attended the Karlsruhe grammar school and later the Karlsruhe Polytechnic University. In 1871, He founded his first company with partner August Ritter, the "Iron Foundry and Machine Shop" a supplier of building materials.

Benz began his work on a two-stroke engine, in hopes of finding a new income. He received his first patent in 1879. In 1883, he founded Benz & Company to produce industrial engines in Mannheim, Germany. He then began designing a "motor carriage", with a four-stroke engine (based on Nicolaus Otto's patent). Benz designed his engine (958cc, 0.75hp) and the body for the three-wheel vehicle with an electric ignition, differential gears, and water-cooling. The car was first driven in Mannheim in

1885. On January 29, 1886, he was granted a patent for his gas-fueled automobile (DRP 37435) and in July, he began selling his automobile to the public. In 1893, the Benz Velo became the world's first inexpensive, mass-produced car.

In 1903, Karl Benz retired from Benz & Company; his designs were already outdated by Gottlieb Daimler. He served as a member of the supervisory board of Daimler-Benz AG from 1926, when the company was formed, until his death.

3.3. The Importance of Gottlieb Daimler



In 1885, Gottlieb Daimler (together with his design partner Wilhelm Maybach) took Otto's internal combustion engine a step further and patented what is generally recognized as the prototype of the modern gas.

The 1885 Daimler-Maybach engine was small, lightweight, fast, used a gasoline-injected carburetor, and had a vertical cylinder. The size, speed, and efficiency of the engine allowed for a revolution in car design. On March 8, 1886, Daimler took a stagecoach and adapted it to hold his engine, thereby designing the world's **first** four-wheeled automobile. Daimler is considered the first inventor to have invented a practical internal-combustion engine.

In 1889, Daimler invented a V-slanted two cylinder, four-stroke engine with mushroom-shaped valves. Just like Otto's 1876 engine, Daimler's new engine set the basis for all car engines going forward. Also in 1889, Daimler and Maybach built their first automobile from the ground up, they did not adapt another purpose vehicle as they had always been done engine. Daimler's connection to Otto was a direct one; Daimler worked as technical director of Deutz Gasmotorenfabrik, which Nikolaus Otto co-owned in 1872. There is some controversy as to who built the first motorcycle Otto or Daimler previously. The new Daimler automobile had a four-speed transmission and obtained speeds of 10 mph. The man who is widely credited with pioneering the modern automobile industry apparently did not like to drive and may never have driven at all. Certainly Gottlieb Daimler was a passenger in 1899 during a rough, bad weather journey that accelerated his declining health and contributed to his death the following spring. Daimler, pioneer of the modern internal combustion engine, was a

workaholic before the term was invented. A relentless perfectionist, he drove himself and his co-workers mercilessly. He did not invent the internal combustion engine, but he improved it. With his partner Wilhelm Maybach, he made engines small, lightweight and fast-running, which made the automotive revolution possible. Daimler was a cosmopolitan man, instrumental in founding auto industries in Germany, France and England. His core competency was engines, and he didn't care whether they were powering cars, boats, trams, pumps or airships. Daimler was born in Schomdorf, Germany in 1834. Early in his engineering career, he became convinced steam engines were an outmoded form of power, and he started building experimental gas engines. He was difficult to get along with, and he left a series of engineering firms because they did not share his vision or his work ethic. At one of them he met Maybach, a man who understood him. Maybach became his partner, inseparable friend and engineering soulmate. In 1872, Daimler worked as technical director of Deutz Gasmotorenfabrik, where one partner was Nikolaus Otto, a pioneer of the four-stroke engine. Daimler assembled a team of the best people from all the shops he had previously worked in, with Maybach on the top of the list. He insisted on the utmost precision and he instituted a system of inspections. By 1874, they were making two engines a day, but Daimler was unsatisfied. He wanted to spend more on research and development, while Otto wanted to produce more engines. Daimler left. In Cannstatt, he and Maybach patented their four-stroke engine in 1885. That same year, they created what was probably the world's first motorcycle by mating a Daimler engine to a bicycle. In 1886, they adapted an engine to a horse carriage. In 1889, they made their first purpose-built automobile and founded Daimler Motoren Gesellschaft. Ten years later, Maybach designed the first car named Mercedes, after his daughter. During this period, Daimler was persuaded by a group of investors to take his company public. They seized majority control and eventually blackmailed him into selling his own shares. Daimler became bitter. With his health failing in the autumn of 1899, he was told to stay in bed, but the workaholic insisted on being driven in bad weather to inspect a possible factory site. On the way home he collapsed and fell out of the car. He died with his family around him early on March 6, 1900. Gottlieb Daimler was an engineer with a peerless ability to synthesize ideas others had developed before and to create something better. That spirit lives still in the industry today.

3.4. The Importance of Henry Ford (1863-1947)

Automobile manufacturer Henry Ford was born July 30, 1863, on his family's farm in Dearborn, Michigan. From the time he was a young boy, Ford enjoyed tinkering with machines. Farm work and a job in a Detroit machine shop afforded him ample opportunities to experiment. He later worked as a part-time employee for the Westinghouse Engine Company. By 1896, Ford had constructed his first horseless carriage which he sold in order to finance work on an improved model. Ford incorporated the Ford Motor Company in 1903, proclaiming, "I will build a car for the great multitude." In October 1908, he did so, offering the Model T for \$950. In the Model T's nineteen years of production, its price dipped as low as \$280. Nearly 15,500,000 were sold in the United States alone. The Model T heralds the beginning of the Motor Age; the car evolved from luxury item for the well-to-do to essential transportation for the ordinary man.

Ford revolutionized manufacturing. By 1914, his Highland Park, Michigan plant, using innovative production techniques, could turn out a complete chassis every 93 minutes. This was a stunning improvement over the earlier production time of 728 minutes. Using a constantly-moving assembly line, subdivision of labor, and careful coordination of operations, Ford realized huge gains in productivity. In 1914, Ford began paying his employees five dollars a day, nearly doubling the wages offered by other manufacturers. He cut the workday from nine to eight hours in order to convert the factory to a three-shift workday. Ford's mass-production techniques would eventually allow for the manufacture of a Model T every 24 seconds. His innovations made him an international celebrity. Ford's affordable Model T irrevocably altered American society. As more Americans owned cars, urbanization patterns changed. The United States saw the growth of suburbia, the creation of a national highway system, and a population entranced with the possibility of going anywhere anytime. Ford witnessed many of these changes during his lifetime, all the while personally longing for the agrarian lifestyle of his youth. In the years prior to his death on April 7, 1947, Ford sponsored the restoration of an idyllic rural town called Greenfield Village. Henry Ford made it possible for the average person to own a car. By building a moving assembly line at a plant in Highland Park, Michigan, Ford was able to increase the output of Model Ts while lowering the cost per unit dramatically. Ford's rise to greatness was slow. The Ford Motor Co. was not founded until 1903, when he

was 40. The revolutionary Model T wasn't introduced until 1908. But the first car he built - the "quadricycle" in 1896 - showed signs of his ultimate greatness. "What was distinctive about the quadricycle," wrote historian John Rae, "was that it was the lightest of the pioneer American gasoline cars and may indicate that Ford was already thinking of a car for the great multitude." Ford was not the only auto industry pioneer with the idea to build a low-priced car. But he differed from his contemporaries in an important way. Others designed cars that could be built cheaply - the result being lightweight buggies that would not stand hard usage. Ford thought that the first requirement was to determine the qualities that a universal car must possess and design it accordingly. Ford soon realized that the Model T would appeal to more than just Americans. A factory in Manchester, England, began making Model Ts in 1911. In 1912, Ford traveled to England to talk with Percival Perry about forming an English company. Ford would also eventually assemble cars in France, Italy and Germany.

In 1928, Ford of Britain was formed. Ford also personally laid the cornerstone for Ford's Cologne factory in 1930. This created Ford's unique dual European strongholds in England and Germany.

3.5. The Importance of Rudolf Diesel

Rudolf Diesel was born in Paris in 1858. His parents were Bavarian immigrants. Rudolf Diesel was educated at Munich Polytechnic. After graduation he was employed as a refrigerator engineer. However, his true love lay in engine design. Rudolf Diesel designed many heat engines, including a solar-powered air engine. In 1893, he published a paper describing an engine with combustion within a cylinder, the internal combustion engine. In 1894, he filed for a patent for his new invention, dubbed the diesel engine. Rudolf Diesel was almost killed by his engine when it exploded. However, his engine was the first that proved that fuel could be ignited without a spark. He operated his first successful engine in 1897. In 1898, Rudolf Diesel was granted patent #608,845 for an "internal combustion engine" the Diesel engine. The diesel engines of today are refined and improved versions of Rudolf Diesel's original concept. They are often used in submarines, ships, locomotives, and large trucks and in electric generating plants. Though best known for his invention of the pressure-ignited heat engine that bears his name, Rudolf Diesel was also a well-respected thermal engineer and a social theorist. Rudolf Diesel's inventions have

three points in common: They relate to heat transference by natural physical processes or laws; they involve markedly creative mechanical design; and they were initially motivated by the inventor's concept of sociological needs. Rudolf Diesel originally conceived the diesel engine to enable independent craftsmen and artisans to compete with large industry. At Augsburg, on August 10, 1893, Rudolf Diesel's prime model, a single 10-foot iron cylinder with a flywheel at its base, ran on its own power for the first time. Rudolf Diesel spent two more years making improvements and in 1896 demonstrated another model with the theoretical efficiency of 75 percent, in contrast to the ten percent efficiency of the steam engine. By 1898, Rudolf Diesel was a millionaire. His engines were used to power pipelines, electric and water plants, automobiles and trucks, and marine craft, and soon after were used in mines, oil fields, factories, and transoceanic shipping.

He set up a laboratory in Paris in 1885, and took out his first patent in 1892. In August 1893 he went to Augsburg, Germany, where he showed the forerunner of MAN AG (Maschinenfabrik Augsburg-Nuerenberg) a three-meter-long iron cylinder with a piston driving a flywheel. It was an economic thermodynamic engine to replace the steam engine. Diesel called it an atmospheric gas engine, but the name didn't stick. He worked on. On New Year's Eve 1896 he proudly displayed an engine that had a theoretical efficiency of 75.6 percent. Of course, this theoretical efficiency could not be attained, but there was nothing to equal it -- and there is nothing to equal it to this day -- in thermodynamic engines. The self-igniting engine was a sensation of the outgoing century, though Rudolf Diesel's dream of enabling the small craftsmen to withstand the power of big industry did not ripen. Instead, big industry quickly took up his idea, and Diesel became very rich with his royalties. From all over the world money flowed to him as his engines became the standard to power ships, electric plants, pumps and oil drills. In 1908 Diesel and the Swiss mechanical firm of Saurer created a faster-running engine that turned at 800 rpm, but the automotive industry was slower to adopt Diesel's engine.

MAN was the first, and in 1924, a MAN truck became the first vehicle to use a direct-injection diesel engine. At the same time Benz & Cie in Germany also presented a diesel truck, but Benz used the mixing chamber that Daimler-Benz kept into the 1990s. The first diesel Mercedes-Benz hit the road in 1936. But Rudolph Diesel didn't

get to see his inventions' victorious march through the automotive world. He drowned in 1913 in the English Channel.

4. Types of engines

There are two major cycles used in internal combustion engines: Otto and Diesel. The Otto cycle is named after Nikolaus Otto (1832 – 1891) who developed a four-stroke engine in 1876. It is also called a spark ignition (**SI**) engine, since a spark is needed to ignite the fuel-air mixture. The Diesel cycle engine is also called a compression ignition (**CI**) engine, since the fuel will auto-ignite when injected into the combustion chamber. The Otto and Diesel cycles operate on either a four- or two-stroke cycle.

Since the invention of the internal combustion engine many pistons-cylinder geometries have been designed. The choice of given arrangement depends on a number of factors and constraints, such as engine balancing and available volume:

- in line
- horizontally opposed
- radial
- V

4.1. In Line

The inline-four engine or straight-four engine is an internal combustion engine with all four cylinders mounted in a straight line, or plane along the crankcase. The single bank of cylinders may be oriented in either a vertical or an inclined plane with all the pistons driving a common crankshaft. Where it is inclined, it is sometimes called a slant-four. In a specification chart or when an abbreviation is used, an inline-four engine is listed either as I4 or L4.

The inline-four layout is in perfect primary balance and confers a degree of mechanical simplicity which makes it popular for economy cars. However, despite its simplicity, it suffers from a secondary imbalance which causes minor vibrations in smaller engines. These vibrations become worse as engine size and power increase,

so the more powerful engines used in larger cars generally are more complex designs with more than four cylinders.

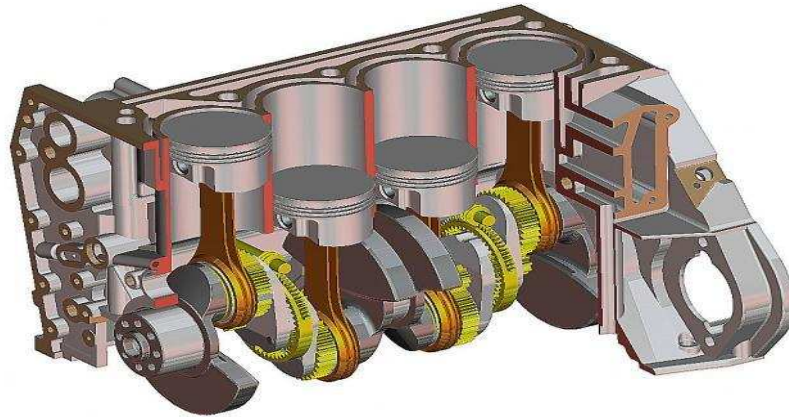

Today almost all manufacturers of four cylinder engines for automobiles produce the inline-four layout, with Subaru's flat-four being a notable exception, and so four cylinder is synonymous with and a more widely used term than inline-four. The inline-four is the most common engine configuration in modern cars, while the V6 is the second most popular. In the late 2000s, with auto manufacturers making efforts to increase fuel efficiency and reduce emissions, due to the high price of oil and the economic recession, the proportion of new vehicles with four cylinder engines (largely of the inline-four type) has risen from 30 percent to 47 percent between 2005 and 2008, particularly in mid-size vehicles where a decreasing number of buyers have chosen the V6 performance option.

Usually found in four- and six-cylinder configurations, the straight engine, or inline engine is an internal combustion engine with all cylinders aligned in one row, with no offset.

A straight engine is considerably easier to build than an otherwise equivalent horizontally opposed or V-engine, because both the cylinder bank and crankshaft can be milled from a single metal casting, and it requires fewer cylinder heads and camshafts. In-line engines are also smaller in overall physical dimensions than designs such as the radial, and can be mounted in any direction. Straight configurations are simpler than their V-shaped counterparts. They have a support bearing between each piston as compared to "flat and V" engines which have

support bearings between every two pistons. Although six-cylinder engines are inherently balanced, the four-cylinder models are inherently off balance and rough, unlike 90 degree V fours and horizontally opposed 'boxer' 4 cylinders.

An even-firing inline-four engine is in primary balance because the pistons are moving in pairs, and one pair of pistons is always moving up at the same time as the other pair is moving down. However, piston acceleration and deceleration are greater in the top half of the crankshaft rotation than in the bottom half, because the connecting rods are not infinitely long, resulting in a non sinusoidal motion. As a result, two pistons are always accelerating faster in one direction, while the other two are accelerating more slowly in the other direction, which leads to a secondary dynamic imbalance that causes an up-and-down vibration at twice crankshaft speed. This imbalance is tolerable in a small, low-displacement, low-power configuration, but the vibrations get worse with increasing size and power.

The reason for the piston's higher speed during the 180° rotation from mid-stroke through top-dead-centre, and back to mid-stroke, is that the minor contribution to the piston's up/down movement from the connecting rod's change of angle here has the same direction as the major contribution to the piston's up/down movement from the up/down movement of the crank pin. By contrast, during the 180° rotation from mid-stroke through bottom-dead-centre and back to mid-stroke, the minor contribution to the piston's up/down movement from the connecting rod's change of angle has the opposite direction of the major contribution to the piston's up/down movement from the up/down movement of the crank pin.

Four cylinder engines also have a smoothness problem in that the power strokes of the pistons do not overlap. With four cylinders and four strokes to complete in the four-stroke cycle, each piston must complete its power stroke and come to a complete stop before the next piston can start a new power stroke, resulting in a pause between each power stroke and a pulsating delivery of power. In engines with more cylinders, the power strokes overlap, which gives them a smoother delivery of power and less vibration than a four can achieve. As a result, six- and eight- cylinder engines are generally used in more luxurious and expensive cars

When a straight engine is mounted at an angle from the vertical it is called a slant engine. Chrysler's Slant 6 was used in many models in the 1960s and 1970s. Honda also often mounts its straight-4 and straight-5 engines at a slant, as on

the Honda S2000 and Acura Vigor. SAAB first used an inline-4 tilted at 45 degrees for the Saab 99, but later versions of the engine were less tilted.

Two main factors have led to the recent decline of the straight-6 in automotive applications. First, Lanchester balance shafts, an old idea reintroduced by Mitsubishi in the 1980s to overcome the natural imbalance of the straight-4 engine and rapidly adopted by many other manufacturers, have made both straight-4 and V6-engine smoother-running; the greater smoothness of the straight-6 layout is no longer such an advantage. Second, fuel consumption became more important, as cars became smaller and more space-efficient. The engine bay of a modern small or medium car, typically designed for a straight-4, often does not have room for a straight-6, but can fit a V6 with only minor modifications.

Straight-6 engines are used in some models from BMW, Ford Australia, Chevrolet, GMC, Toyota, Suzuki and Volvo Cars.

4.2. Horizontally opposed

A horizontally opposed engine is an engine in which the two cylinder heads are on opposite side of the crankshaft, resulting in a flat profile. Subaru and Porsche are two automakers that use horizontally opposed engine in their vehicles.

Horizontally opposed engines offer a low centre of gravity and thereby may a drive configuration with better stability and control. They are also wider than other engine configurations, presenting complications with the fitment of the engine within the engine bay of a front-engine car. This kind of engine is wide spread in the aircraft production.

Typically, the layout has cylinders arranged in two banks on the either side of the single crankshaft and is generally known as boxer.



Boxers got their name because each pair of piston moves simultaneously in and out, rather than alternately, like boxers showing they are ready by clashing their gloved fists against each other before a fight. Boxer engines of up to eight cylinders have proved highly successful in automobiles and up to six in motorcycles and continue to be popular for the light aircrafts engine.

Boxers are one of only three cylinder layouts that have a natural dynamic balance; the others being the straight-6 and the V12. These engines can run very smoothly and free of unbalanced forces with a four-stroke cycle and do not require a balance shaft or counterweights on the crankshaft to balance the weight of the reciprocating parts, which are required in other engine configurations. However, in the case of boxer engines with fewer than six cylinders, unbalanced moments (a reciprocating torque also known as a "rocking couple") are unavoidable due to the "opposite" cylinders being slightly out of line with each other.

Boxer engines (and flat engines in general) tend to be noisier than other common engines for both intrinsic and other reasons, valve clatter from under the hood is not damped by large air filters and other components. Boxers need no balance weights on the crankshaft, which should be lighter and fast-accelerating - but, in practice (e.g. in cars), they need a flywheel to run smoothly at low speeds and this negates the advantage. They have a characteristic smoothness throughout the rev range and offer a low centre of gravity

4.3. Radial Engine

The radial engine is a reciprocating type internal combustion engine configuration in which the cylinders point outward from a central crankshaft like the spokes on a wheel. This configuration was very commonly used in large aircraft engines before most large aircraft started using turbine engines.

In a radial engine, the pistons are connected to the crankshaft with a master-and-articulating-rod assembly. One piston has a master rod with a direct attachment to the crankshaft. The remaining pistons pin their connecting rods' attachment to rings around the edge of the master rod. Four-stroke radials always have an odd number cylinders per row, so that a consistent every-other-piston firing order can be maintained, providing smooth operation. This achieved by the engine taking two revolution of the crankshaft to complete the four strokes (intake, compression, power, exhaust), which means the firing order is 1,3,5,2,4 and back to cylinder 1 again. This means that there is always a two-piston gap between the piston on its power stroke and the next piston on fire (piston compression). If an even number of cylinders was uses, the firing order would be something similar to 1,3,5,2,4,6 which leaves a three-piston gap between firing piston on the first crank shaft revolution and only one-piston gap on the second. This leads to an uneven firing order within the engine, and is not ideal.

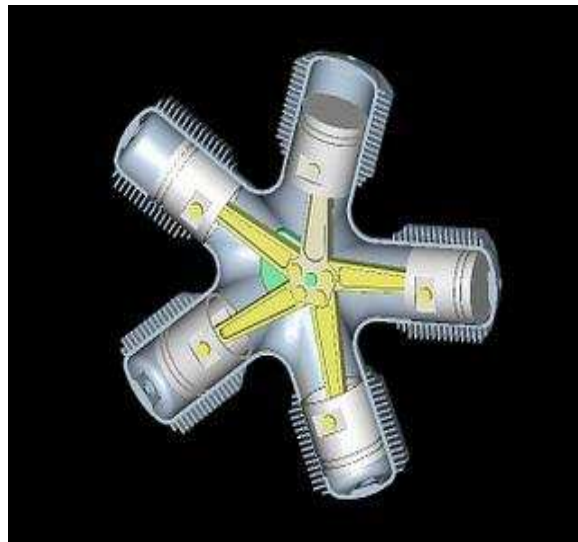

Originally radial engines had one row of cylinders, but as engine sizes increased it become necessary to add extra rows. The first known radial-configuration engine

using a twin-row was “Double Lambda” from 1912, designed as a 14 cylinder twin-row version.

While most radial engines have been produced for gasoline fuels, there have been instances of diesel fueled engines. The Bristol Phoenix of 1928-1932 was successfully tested in aircraft and the Nordberg Manufacturing Company of the US developed and produce series of large diesel engines from the 1940s.

The companies that build rotary engines nowadays are Vedeneyev, Rotec Engineering, HCl Aviation and Verner Motors.

4.4. V engine

V engine or Vee engine is a common configuration for an internal combustion engine. The cylinders and pistons are aligned in two separate planes or “banks”, is that they appear to be in a “V” when viewed along the axis of the crankshaft. The Vee configuration generally reduces the overall engine length, height and weight compared to the equivalent inline configuration.

Various cylinder bank angles of Vee are used in different engines depending on the number of the cylinders; there may be angles that work better than others for stability. Very narrow angles of V combine some of the advantages of the straight and V engine.

The most common of V engines is V6. It is an engine with six cylinders mounted on the crankcase in two banks of three cylinders, usually set at either a right angle or an accurate angle to each other, with all six pistons driving a common crankshaft. It is second common engine configuration in modern cars after the inline-four.

It is becoming more common as the space allowed in modern cars is reduced at the time as power requirements increase, and has largely replaced the inline-6, which is too long to fit in the many modern engine compartments. Although it is more complicated and not as smooth as the inline-6, the V6 is more rigid for a given weight, more compact and less prone to torsional vibrations in the crankshaft for a given displacement. The V6 engine has become widely adopted for medium-sized cars, often as an optional engine where a straight 4 is standard, or as a base engine where a V8 is a higher-cost performance.



The most efficient cylinder bank angle for V6 is 60 degrees, minimizing size and vibration. While 60 degrees V6 are not as well balanced as inline-6 and flat-6 engines, modern techniques for designing and mounting engines have largely disguised their vibrations. Unlike most others angles, 60 degree V6 engines can be made acceptably smooth without the need for balance shafts.

90° V6 engines are also produced, usually so they can use the same production-line tooling set up to produce V8 engines (which normally have a 90° V angle). Although it is easy to derive a 90° V6 from an existing V8 design by simply cutting cylinders off the engine, this tends to make it wider and more vibration-prone than a 60° V6.

120° might be described as the natural angle for a V6 since the cylinders fire every 120° of crankshaft rotation. Unlike the 60° or 90° configuration, it allows pairs of pistons to share crank pins in a three-throw crankshaft without requiring flying arms or split crankpins to be even-firing. The 120° layout also produces an engine which is too wide for most automobile engine compartments, so it is more often used in racing cars where the car is designed around the engine rather than vice-versa, and vibration is not as important.

5. Main components of the engine

5.1. Piston

Piston is one of the main parts in the engine. Its purpose is to transfer force from expanding gas in the cylinder to the crankshaft via a connecting rod.

Since the piston is the main reciprocating part of an engine, its movement creates an imbalance. This imbalance generally manifests itself as a vibration, which causes the engine to be perceivably harsh. The friction between the walls of the cylinder and the piston rings eventually results in wear, reducing the effective life of the mechanism.

The sound generated by a reciprocating engine can be intolerable and as a result, many reciprocating engines rely on heavy noise suppression equipment to diminish droning and loudness. To transmit the energy of the piston to the crank, the piston is connected to a connecting rod which is in turn connected to the crank. Because the linear movement of the piston must be converted to a rotational movement of the crank, mechanical loss is experienced as a consequence. Overall, this leads to a decrease in the overall efficiency of the combustion process. The motion of the crank shaft is not smooth, since energy supplied by the piston is not continuous and it is impulsive in nature. To address this, manufacturers fit heavy flywheels which supply constant inertia to the crank. Balance shafts are also fitted to some engines, and diminish the instability generated by the pistons movement. To supply the fuel and remove the exhaust fumes from the cylinder there is a need for valves and camshafts. During opening and closing of the valves, mechanical noise and vibrations may be encountered.



Pistons are commonly made of a cast aluminum alloy for excellent and lightweight thermal conductivity. Thermal conductivity is the ability of a material to conduct and transfer heat. Aluminum expands when heated, and proper clearance must be provided to maintain free piston movement in the cylinder bore. Insufficient clearance can cause the piston to seize in the cylinder. Excessive clearance can cause a loss of compression and an increase in piston noise.

Piston features include the piston head, piston pin bore, piston pin, skirt, ring grooves, ring lands, and piston rings. The *piston head* is the top surface (closest to the cylinder head) of the piston which is subjected to tremendous forces and heat during normal engine operation.

A *piston pin bore* is a through hole in the side of the piston perpendicular to piston travel that receives the piston pin. A *piston pin* is a hollow shaft that connects the small end of the connecting rod to the piston. The *skirt* of a piston is the portion of the piston closest to the crankshaft that helps align the piston as it moves in the cylinder bore. Some skirts have profiles cut into them to reduce piston mass and to provide clearance for the rotating crankshaft counterweights

5.2. Piston Rings

A *ring groove* is a recessed area located around the perimeter of the piston that is used to retain a piston ring. *Ring lands* are the two parallel surfaces of the ring groove which function as the sealing surface for the piston ring. A *piston ring* is an expandable split ring used to provide a seal between the piston and the cylinder wall. Piston rings are commonly made from cast iron. Cast iron retains the integrity of its original shape under heat, load, and other dynamic forces. Piston rings seal the combustion chamber, conduct heat from the piston to the cylinder wall, and return oil to the crankcase. Piston ring size and configuration vary depending on engine design and cylinder material.

Piston rings commonly used on small engines include the compression ring, wiper ring, and oil ring. A *compression ring* is the piston ring located in the ring groove closest to the piston head. The compression ring seals the combustion chamber from any leakage during the combustion process. When the air-fuel mixture is ignited, pressure from combustion gases is applied to the piston head, forcing the piston toward the crankshaft. The pressurized gases travel through the gap between the cylinder wall and the piston and into the piston ring groove. Combustion gas pressure forces the piston ring against the cylinder wall to form a seal. Pressure applied to the piston ring is approximately proportional to the combustion gas pressure.

A *wiper ring* is the piston ring with a tapered face located in the ring groove between the compression ring and the oil ring. The wiper ring is used to further seal the combustion chamber and to wipe the cylinder wall clean of excess oil. Combustion gases that pass by the compression ring are stopped by the wiper ring.

An *oil ring* is the piston ring located in the ring groove closest to the crankcase. The oil ring is used to wipe excess oil from the cylinder wall during piston movement. Excess oil is returned through ring openings to the oil reservoir in the engine block. Two-stroke cycle engines do not require oil rings because lubrication is supplied by mixing oil in the gasoline, and an oil reservoir is not required.

Piston rings seal the combustion chamber, transferring heat to the cylinder wall and controlling oil consumption. A piston ring seals the combustion chamber through inherent and applied pressure. Inherent pressure is the internal spring force that expands a piston ring based on the design and properties of the material used. Inherent pressure requires a significant force needed to compress a piston ring to a

smaller diameter. Inherent pressure is determined by the uncompressed or free piston ring gap. Free piston ring gap is the distance between the two ends of a piston ring in an uncompressed state. Typically, the greater the free piston ring gap, the more force the piston ring applies when compressed in the cylinder bore.

A piston ring must provide a predictable and positive radial fit between the cylinder wall and the running surface of the piston ring for an efficient seal. The radial fit is achieved by the inherent pressure of the piston ring. The piston ring must also maintain a seal on the piston ring lands.



In addition to inherent pressure, a piston ring seals the combustion chamber through applied pressure. Applied pressure is pressure applied from combustion gases to the piston ring, causing it to expand. Some piston rings have a chamfered edge opposite the running surface. This chamfered edge causes the piston ring to twist when not affected by combustion gas pressures.

The piston acts as the movable end of the combustion chamber and must withstand pressure fluctuations, thermal stress, and mechanical load. Piston material and design contribute to the overall durability and performance of an engine. Most pistons are made from die- or gravity-cast aluminum alloy. Cast aluminum alloy is lightweight and has good structural integrity and low manufacturing costs. The light weight of aluminum reduces the overall mass and force necessary to initiate and maintain acceleration of the piston. This allows the piston to utilize more of the force produced by combustion to power the application. Piston designs are based on benefits and compromises for optimum overall engine performance

5.3. Connecting Rod

The connecting rod is a major link inside of a combustion engine. It connects the piston to the crankshaft and is responsible for transferring power from the piston to the crankshaft and sending it to the transmission. There are different types of materials and production methods used in the creation of connecting rods. The most common types of connecting rods are steel and aluminum. The most common type of manufacturing processes are casting, forging and powdered metallurgy.

The connecting rod is the most common cause of catastrophic engine failure. It is under an enormous amount of load pressure and is often the recipient of special care to ensure that it does not fail prematurely. The sharp edges are sanded smooth in an attempt to reduce stress risers on the rod. The connecting rod is also shot-peened, or hardened, to increase its strength against cracking. In most high-performance applications, the connecting rod is balanced to prevent unwanted harmonics from creating excessive wear.

The most common connecting rod found in production vehicle engines is a cast rod. This type of rod is created by pouring molten steel into a mold and then machining the finished product. This type of rod is reliable for lower horsepower-producing engines and is the least expensive to manufacture. The cast rod has been used in nearly every type of engine, from gasoline to diesel, with great success.



5.4. Crankshaft

The crankshaft is the part of an engine which translates reciprocating linear piston motion into rotation. To convert the reciprocating motion into rotation, the crankshaft has crankpins, additional bearing surfaces whose axis is offset from that of the crank, to which the “big ends” of the connecting rod from each cylinder attach.

It typically connects to a flywheel, to reduce the pulsation characteristic of the four-stroke cycle, and sometimes a torsional or vibrational damper at the opposite end, to reduce the torsion vibrations often caused along the length of the crankshaft by the cylinders farthest from the output end acting on the torsion elasticity of the metal.



The engine's crankshaft is made of very heavy cast iron in most cases and solid steel in very high-performance engines. The crankshaft's snout must be made very strong to withstand the stress of placing the crankshaft pulley and the stress created from driving all of the components off of that single pulley.

5.5. *Camshaft*

Camshaft is frequently called “brain” of the engine. This is so because its job is to open and closed at just the right time during engine rotation, so that the maximum power and efficient cleanout of exhaust to be obtained. The camshaft drives the distributor to electrically synchronize spark ignition. Camshafts do their work through eccentric "lobes" that actuate the components of the valve train. The camshaft itself is forged from one piece of steel, on which the lobes are ground. On single-camshaft engines there are twice as many lobes as there are cylinders, plus a lobe for fuel pump actuation and a drive gear for the distributor. Driving the camshaft is the crankshaft, usually through a set of gears or a chain or belt. The camshaft always rotates at half of crank rpm, taking two full rotations of the crankshaft to complete one rotation of the cam, to complete a four-stroke cycle. The camshaft operates the lifters (also called tappets or cam followers) that in turn operate the rest of the valve train. On "overhead valve" engines the lifters move pushrods that move rocker arms that move valve stems. Lifters can be of several types. The most common are hydraulic, mechanical and roller lifters. Hydraulic lifters fill with oil that acts as a shock absorber to eliminate clearance in the valve train. They are quiet and don't require periodic adjustment. Mechanical lifters are solid metal and require scheduled adjustment for proper valve clearance. These are used in high-rpm applications. Roller lifters use a roller device at one end and can be hydraulic or mechanical. They are used in applications where a very fast rate of valve lift is required.



Overlap is the point in crank rotation when both the intake and exhaust valves are open simultaneously. This happens at the end of the exhaust stroke when the exhaust valve is closing and the intake is opening. During the period of overlap, the intake and exhaust ports can communicate with each other. Ideally, you want the scavenge effect from the exhaust port to pull the air/fuel mixture from the intake port into the combustion chamber to achieve more efficient cylinder filling. A poorly designed cam and port combination, however, can cause reversion, where exhaust gases push their way past the intake valve and into the intake tract.

Several factors influence how much overlap is ideal for your engine. Small combustion chambers typically require minimal overlap, as do engines designed to maximize low-rpm torque. Most current stock car racing engines depend on high rpm to take advantage of better gear ratios, so more overlap is normally helpful. When the revolutions per minute increase, the intake valve is open for a shorter period of time. The same amount of air and fuel must be pulled into the combustion chamber in less time, and the engine can use all the help it can get to fill the chamber. Increasing the overlap can help here.

Duration: The amount of time (in degrees of rotation of the camshaft) that the lobe holds the valve off its seat. Duration also affects the total lift of the valve because of the inherent limitations to the rate-of-lift of the lifter itself. Duration is generally the most important thing to consider when choosing a camshaft. The point where the intake valve opens is critical to an engine's running properly.

If it opens too early, exhaust gases can get forced into the intake manifold. This causes soot buildup on the intake runners, low engine vacuum and low power. If the valve opens too late, less of the fuel/air mixture gets into the combustion chamber and exhaust gases won't be as efficiently removed.

If the exhaust valve closes too early the desired "scavenging effect" will be less and some exhaust gases can get trapped in the cylinder. If the valve closes too late an excessive amount of fuel/air mixture will escape into the exhaust port and the combustion chamber will not be optimized.

The camshaft material should combine a strong shaft with hard cam lobes. The most widely used material at present is chilled or forged cast iron.

6. Kinematics Calculation of a supercharging engine

Given parameter of the engine;

$$R = 32mm;$$

$$L = 142mm;$$

$$D = 81mm;$$

S_x -current value of the piston, [mm]

$$S_x = R \cdot \left[(1 - \cos \varphi) + \frac{1}{\lambda} \cdot (1 - \cos \beta) \right];$$

S_{xI} - movement of the piston first order, [mm]

$$S_{xI} = R \cdot (1 - \cos \varphi);$$

S_{xII} -movement of the piston second order, [mm]

$$S_{xII} = R \cdot \frac{\lambda}{4} \cdot (1 - \cos 2\varphi);$$

where: $\lambda = \frac{R}{L_m} = \frac{32}{142} = 0.23$ is the ratio between the crankshaft and the length of connecting rod ;

$V_{\dot{\sigma}}$ - velocity of the piston, [mm/s]

$$\omega = \frac{\pi \cdot n}{30} = \frac{3,14 \cdot 6000}{30} = 628s^{-1} \text{ - angular velocity of the crankshaft}$$

$$V_{\dot{\sigma}} = \omega \cdot R \cdot \left(\sin \varphi + \frac{\lambda}{2} \cdot \sin 2\varphi \right);$$

$V_{\dot{\sigma}_I}$ - velocity of the piston first order, mm/s

$$V_{\dot{\sigma}_I} = \omega \cdot R \cdot \sin \varphi$$

$V_{\sigma_{II}}$ - velocity of the piston second order, [mm/s]

$$V_{\sigma_{II}} = \omega.R.\frac{\lambda}{2}.\sin 2.\varphi$$

j - acceleration of the piston, mm/s^2

$$j = \omega^2.R.(\cos \varphi + \lambda.\cos 2.\varphi)$$

j_I - acceleration of the piston – first order, [mm/s^2]

$$j_I = \omega^2.R.\cos \varphi$$

j_{II} - acceleration of the piston – second order, [mm/s^2]

$$j_{II} = \omega^2.R.\lambda.\cos 2.\varphi$$

All calculations are presented in the tables below:

ϕ	β	Sx	Sx1	Sx2
grad	grad	m	m	m
0	0	0	0	0
30	8,59	0,005642	0,004555	0,001086
60	15,42	0,020259	0,017	0,003259
90	18,13	0,038346	0,034	0,004346
120	15,42	0,054259	0,051	0,003259
150	8,59	0,064531	0,063445	0,001086
180	0	0,068	0,068	0
210	-11,35	0,064531	0,063445	0,001086
240	-17,05	0,054259	0,051	0,003259
270	-17,55	0,038346	0,034	0,004346
300	-13,51	0,020259	0,017	0,003259
330	-6,08	0,005642	0,004555	0,001086
360	0	0	0	0
390	8,59	0,005642	0,004555	0,001086
420	15,42	0,020259	0,017	0,003259
450	18,13	0,038346	0,034	0,004346
480	15,42	0,054259	0,051	0,003259
510	8,59	0,064531	0,063445	0,001086
540	0	0,068	0,068	0
570	-11,35	0,064531	0,063445	0,001086
600	-17,05	0,054259	0,051	0,003259
630	-18,13	0,038346	0,034	0,004346
660	-15,42	0,020259	0,017	0,003259
690	-8,59	0,005642	0,004555	0,001086
720	0	0	0	0

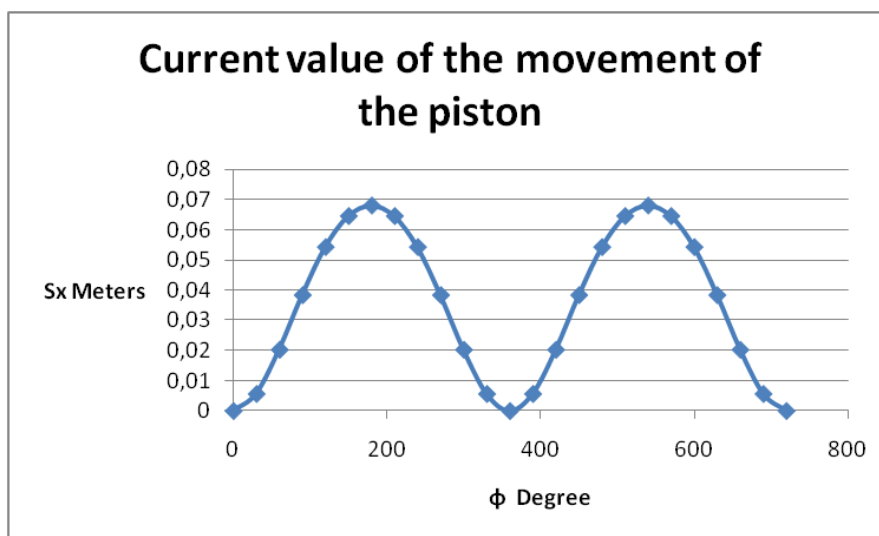

ϕ	β	Vb1	Vb2	Vb
grad	grad	m/s	m/s	m/s
0	0	0	0	0
30	8,59	10,7	2,365	13,046
60	15,42	18,5	2,365	20,866
90	18,13	21,4	0	21,363
120	15,42	18,5	-2,365	16,136
150	8,59	10,7	-2,365	8,316
180	0	0	0	0
210	-11,35	-10,7	2,365	-8,316
240	-17,05	-18,5	2,365	-16,136
270	-17,55	-21,4	0	-21,363
300	-13,51	-18,5	-2,365	-20,866
330	-6,08	-10,7	-2,365	-13,046
360	0	0	0	0
390	8,59	10,7	2,365	13,046
420	15,42	18,5	2,365	20,866
450	18,13	21,4	0	21,363
480	15,42	18,5	-2,365	16,136
510	8,59	10,7	-2,365	8,316
540	0	0	0	0
570	-11,35	-10,7	2,365	-8,316
600	-17,05	-18,5	2,365	-16,136
630	-18,13	-21,4	0	-21,363
660	-15,42	-18,5	-2,365	-20,866
690	-8,59	-10,7	-2,365	-13,046
720	0	0	0	0

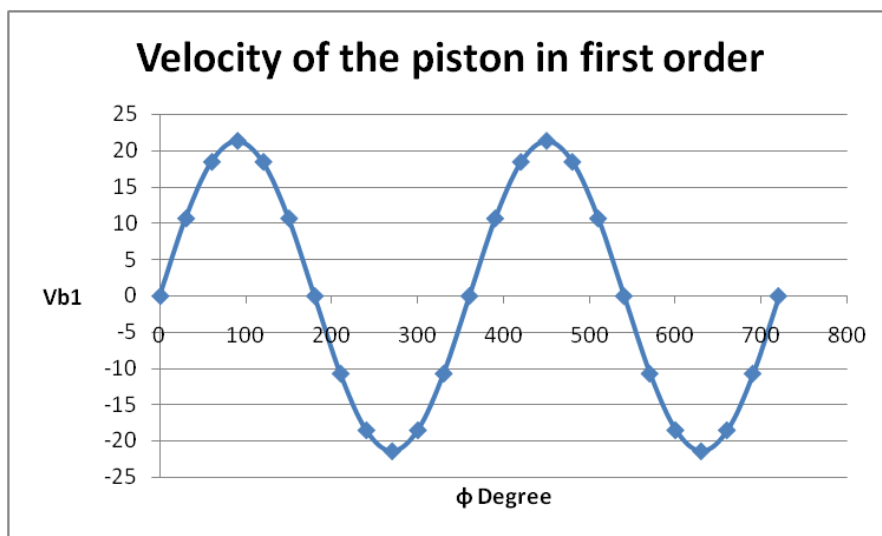

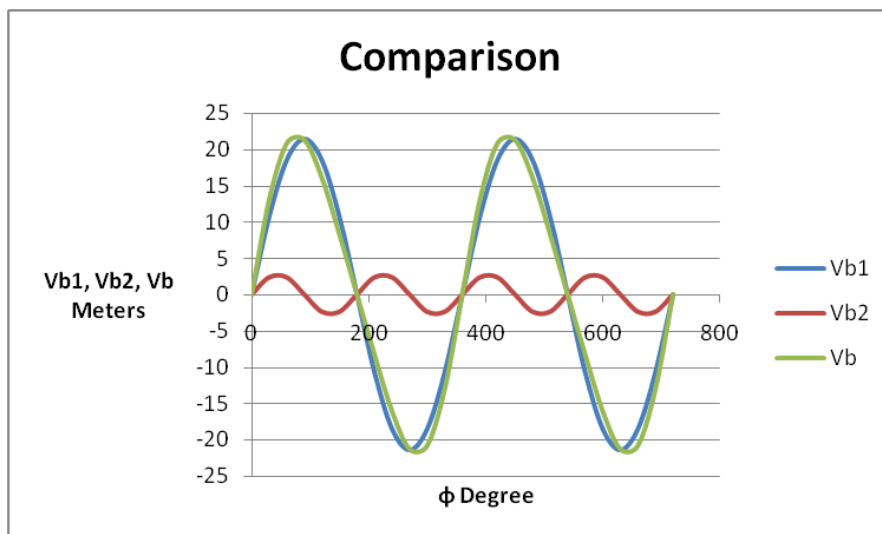
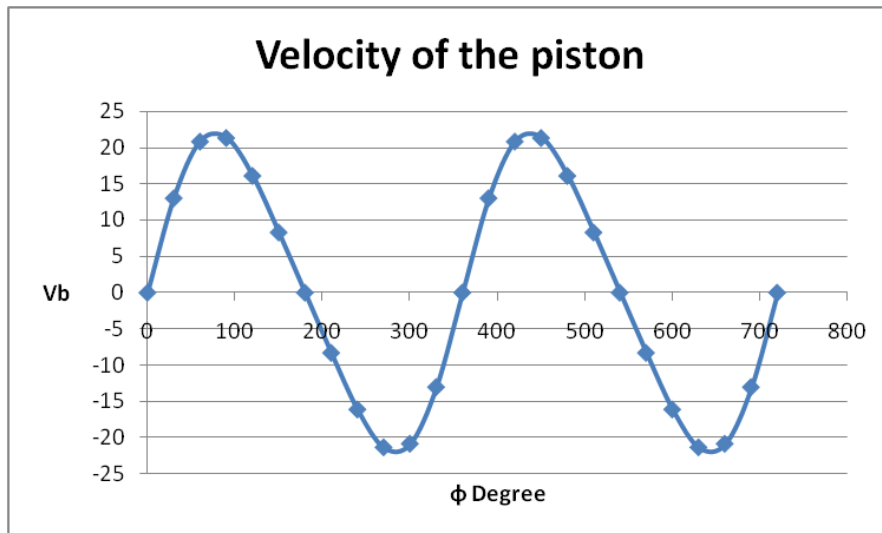
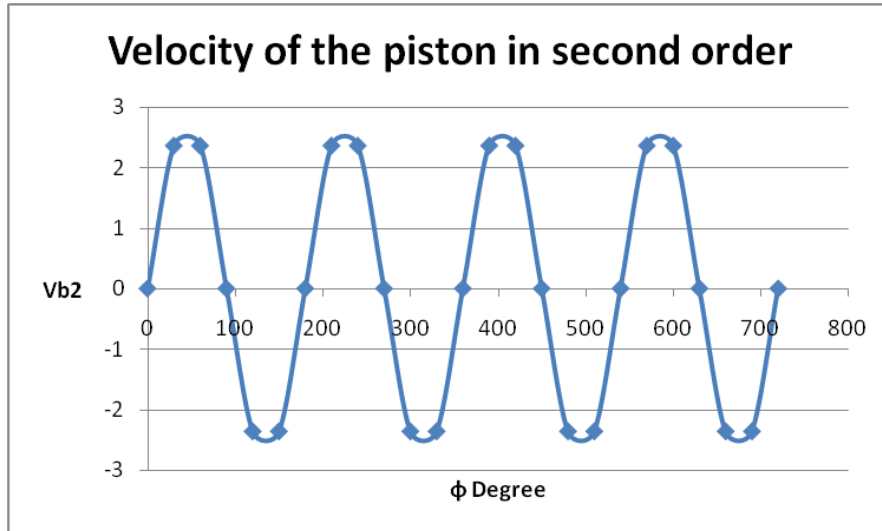

ϕ	β	j1	j2	j
grad	grad	m/s ²	m/s ²	m/s ²
0	0	13422,66	3431,36	16854,02
30	8,59	11624,37	1715,68	13340,04
60	15,42	6711,33	-1715,68	4995,65
90	18,13	0	-3431,36	-3431,36
120	15,42	-6711,33	-1715,68	-8427,01
150	8,59	-11624,4	1715,68	-9908,69
180	0	-13422,7	3431,36	-9991,3
210	-11,35	-11624,4	1715,68	-9908,69
240	-17,05	-6711,33	-1715,68	-8427,01
270	-17,55	0	-3431,36	-3431,36
300	-13,51	6711,33	-1715,68	4995,65
330	-6,08	11624,37	1715,68	13340,04
360	0	13422,66	3431,36	16854,02
390	8,59	11624,37	1715,68	13340,04
420	15,42	6711,33	-1715,68	4995,65
450	18,13	0	-3431,36	-3431,36
480	15,42	-6711,33	-1715,68	-8427,01
510	8,59	-11624,4	1715,68	-9908,69
540	0	-13422,7	3431,36	-9991,3
570	-11,35	-11624,4	1715,68	-9908,69
600	-17,05	-6711,33	-1715,68	-8427,01
630	-18,13	0	-3431,36	-3431,36
660	-15,42	6711,33	-1715,68	4995,65
690	-8,59	11624,37	1715,68	13340,04
720	0	13422,66	3431,36	16854,02

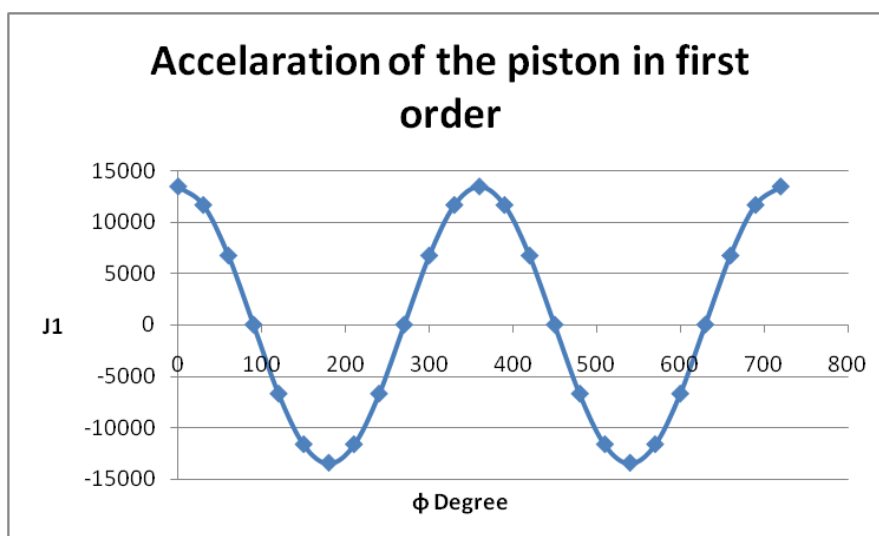

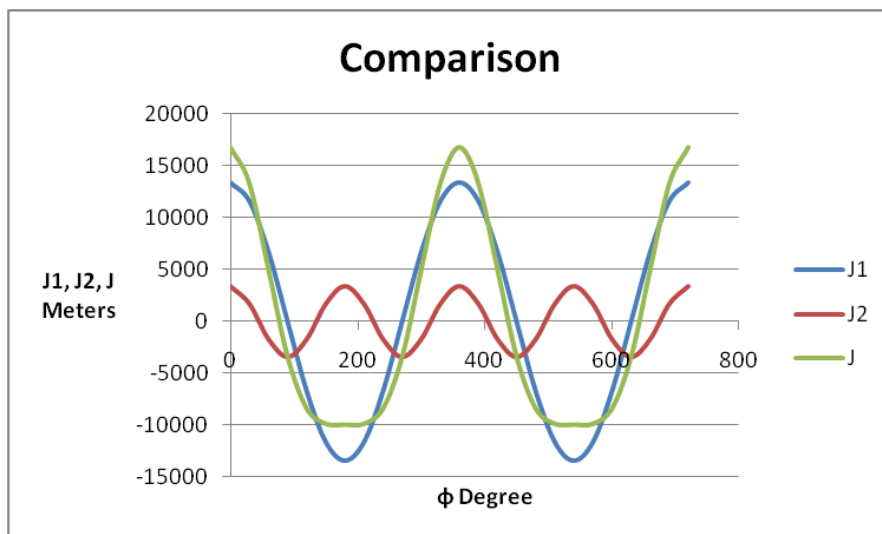
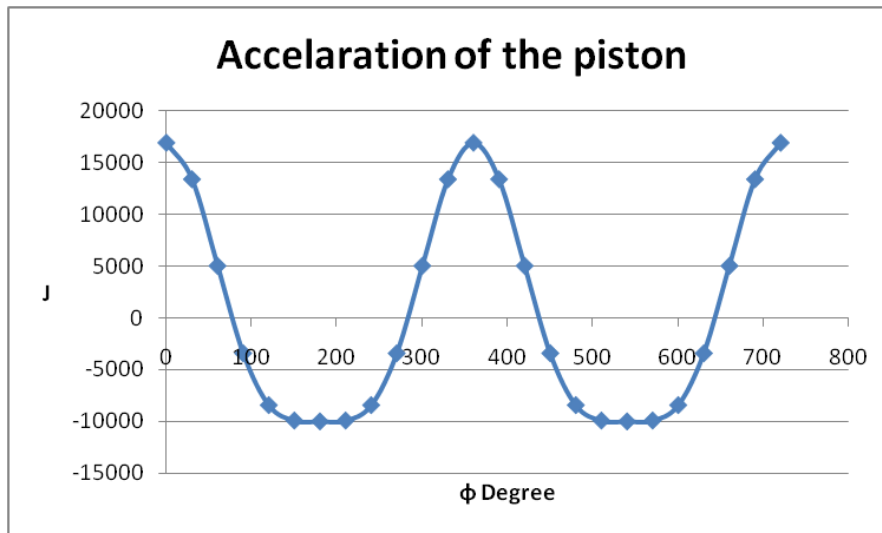
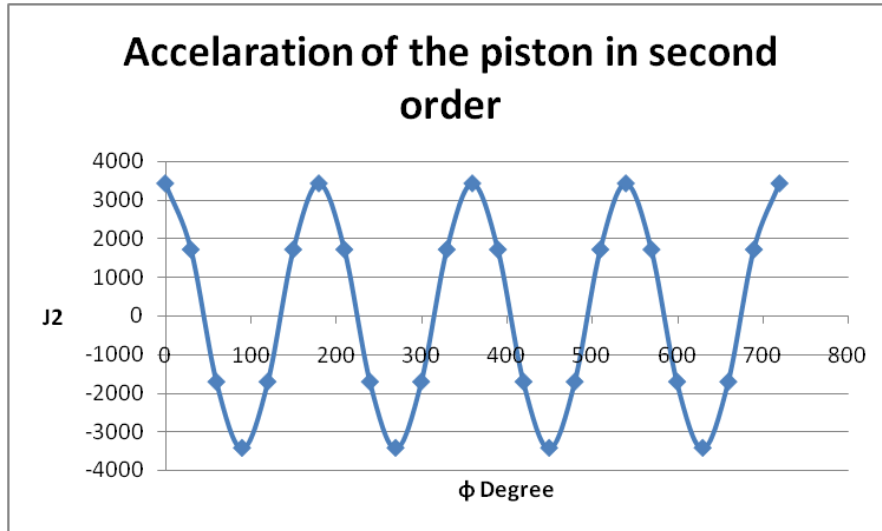

7. Dynamic Calculation of an engine with supercharging

7.1. Gas Forces

Analytical calculation of the gas forces as a function of the angle of rotation of the crankshaft is:

$$P_z = \left[p_n \cdot \left(\frac{S_h + S_c}{S_c + S_x} \right)^n - p_{np} \right] \cdot F_{\sigma} = (p_n B - p_{np}) F_{\sigma}, MN$$

where:

p_n - initial pressure of the process, [MPa]

S_h - working stroke of the piston, [m]

$S_c = \frac{S_h}{\varepsilon - 1}$ - motion, consistent with the height of combustion chamber

p_{np} - pressure acting on the opposite side of the piston, commonly for four-stroke engine $p_{np} = 0,1MPa$

n - index politropata process

$\varphi = 0 \div 180^0 \rightarrow n = 0;$

$\varphi = 180 \div 360^0 \rightarrow n = n_1 = 1,375$

$\varphi = 360 \div 540^0 \rightarrow n = n_2 = 1,25$

$\varphi = 540 \div 720^0 \rightarrow n = 0$

$$S_x = \left[\left(1 + \frac{1}{\lambda} \right) - \left(\cos \varphi + \frac{1}{\lambda} \cdot \cos \beta \right) \right] \cdot R = A \cdot R \quad \text{- current section of the stoke}$$

where:

β - angle of deflection of the connection-rod

7.2. Inertia Forces

Inertial Forces of mass, having liner motion can be calculated by the following expression:

$$P_j = -m_j \cdot \omega^2 \cdot R \cdot \left[\frac{\cos(\varphi + \beta)}{\cos \beta} + \lambda \cdot \frac{\cos^2 \varphi}{\cos^2 \beta} \right] \cdot 10^{-6}, MN$$

where:

$$\omega = \frac{\pi \cdot n}{30} = \frac{3,14 \cdot 6000}{30} = 628 rad / s - \text{angular velocity of the crankshaft}$$

$$m_j - \text{mass of particles having linear motion, [kg]}$$

Inertial Forces of the rotating parts are determined by:

$$P_R = 10^{-6} \cdot m_R \cdot \omega^2 \cdot R = const, MN$$

where:

$$m_j - \text{mass of particles having rotational motion, [kg]};$$

To determine these forces Crank-Connecting Rod mechanism is reduced in equivalent dual mass system m_j and m_R determine by the condition:

$$m_j = m_{\sigma, ep} + m_{\sigma \bar{\sigma}}, kg$$

$$m_R = m_{\kappa} + m_{\sigma \bar{\kappa}}, kg$$

where:

$$m_{\sigma, ep} = 0,703 kg - \text{the mass of piston group (piston and rings, piston pin)}$$

$$m_{\kappa} = 0,811 kg - \text{unstable mass of a crank};$$

$$m_{\sigma} = 0,661 kg - \text{mass of the connecting rod};$$

$m_{\sigma \bar{\sigma}} = m_{\sigma} \cdot 0,25 = 0,661 \cdot 0,25 = 0,165 kg$ - the part of mass of the rod aligned to the axis of the piston pin;

$m_{\sigma \bar{\kappa}} = m_{\sigma} \cdot 0,75 = 0,661 \cdot 0,75 = 0,496 kg$ - the part of mass of the rod aligned to the axis of the crank;

$$m_j = m_{\sigma, ep} + m_{\sigma \bar{\sigma}} = 0,703 + 0,165 = 0,868 kg$$

$$m_R = m_{\kappa} + m_{\sigma \bar{\kappa}} = 0,811 + 0,496 = 1,31 kg$$

7.3. Forces acting on the crank-connection rod mechanism

As a result of operating gas, inertia and centrifugal forces, crank mechanism is loaded with forces that can be calculated analytically by the expression:

$$N = P_{\Sigma} \cdot \tan \beta \text{ - static force, [MN]}$$

$$S = P_{\Sigma} \cdot \frac{1}{\cos \beta} \text{ - force acting along the axis of the rod, [MN]}$$

$$T = P_{\Sigma} \cdot \frac{\sin(\varphi + \beta)}{\cos \beta} \text{ - tangential force, [MN]}$$

$$Z = P_{\Sigma} \cdot \frac{\cos(\varphi + \beta)}{\cos \beta} \text{ [MN]};$$

where:

$$P_{\Sigma} = P_2 + P_j \text{ - the sum of all forces acting on the piston [, MN]}$$

Determination of the Centrifugal Forces:

$P_{R, MK} = 10^{-6} \cdot m_{MK} \cdot R \cdot \omega^2 = 10^{-6} \cdot 0,496 \cdot 0,032 \cdot 628^2 = 0,06245 MN$ - centrifugal force caused by the mass of the connecting rods, reduced to the axis of the crankshaft

$P_{R, \kappa} = 10^{-6} \cdot m_{\kappa} \cdot R \cdot \omega^2 = 10^{-6} \cdot 0,81 \cdot 0,032 \cdot 628^2 = 0,01022 MN$ - centrifugal force generated by unbalanced mass of a crank of the crankshaft.

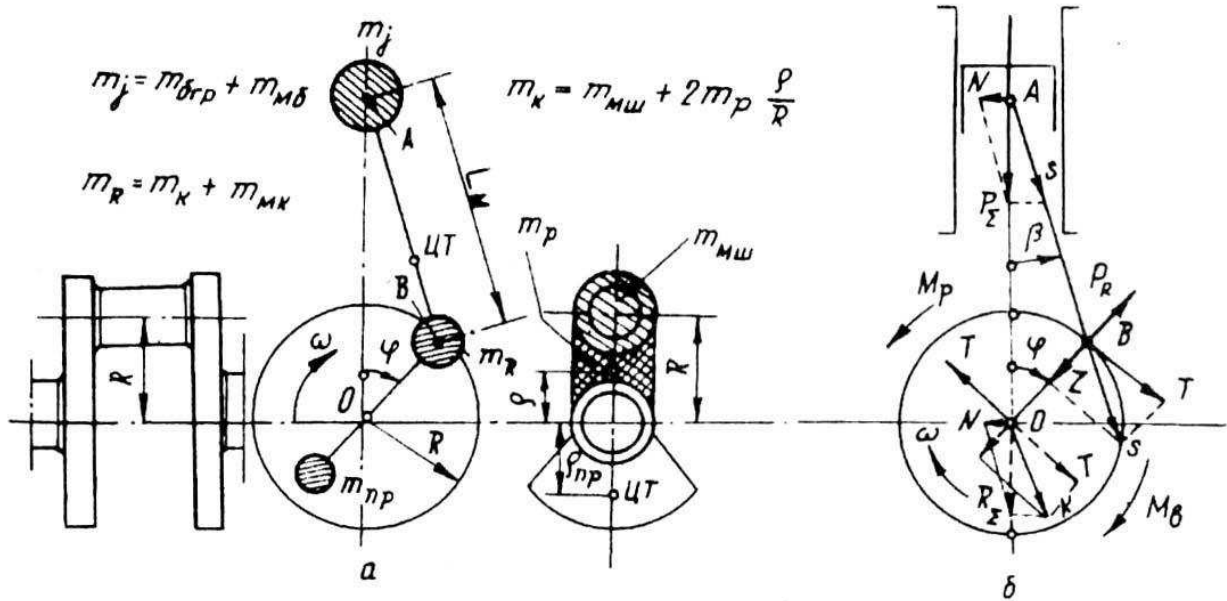

7.4. Connection Rod bearings

Bears include two common elements : journals and plain shaft bearings.

We can determine the force acting on the connecting rod's neck by following expression:

$$P_{\text{mu}} = \sqrt{T^2 + (Z + P_{R_{\text{MK}}})^2}, \text{MN}$$

When we determine journals, we have to take into account mean specific pressure $q_{\text{mu},\text{cp}}$ and max specific pressure $q_{\text{mu},\text{max}}$

$$q_{\text{mu},\text{max}} = \frac{P_{\text{mu},\text{max}}}{d_{\text{mu}} \cdot l_{\text{mu}}}, \text{MPa}$$

$$q_{\text{mu},\text{cp}} = \frac{P_{\text{mu},\text{cp}}}{d_{\text{mu}} \cdot l_{\text{mu}}}, \text{MPa}$$

Where :

$$d_{\text{mu}} = (0,56 \div 0,75) \cdot D \text{ - diameter of connecting rod journals, [m]}$$

$$l_{\text{mu}} = (0,45 \div 0,90) \cdot d_{\text{mu}} \text{ - working width of connecting rod journals, [m]}$$

$$P_{\text{mu},\text{max}} \text{ - maximum value of the force acting on the connection rod journals}$$

$$P_{mu,cp} = \frac{F}{OA} \cdot \mu_P MN \text{ - average value of the actual force acting on the rod}$$

journals

7.5. Equilibration of the engine

Forces and moments acting on crank mechanism, change their direction and value, so if they are not in equilibrium condition they cause vibrations in the engine and its bearings. In engine usually inertia forces of first and second order of reciprocating moving masses P_{j_1} , P_{j_2} , centrifugal forces of rotating mass P_R and their respective moments M_{j_1}, M_{j_2}, M_{PR} remain unbalanced. Reactive moment $M_p = -M_B$, always act on the supports of the engine and cannot be balanced. Therefore, one engine is considered to be balanced, if the following conditions are met:

- Resultant inertia forces in first order and their moments to be zero -
 $\Sigma P_{j_1} = 0$ and $\Sigma M_{j_1} = 0$
- Resultant inertia forces in second order and their moments to be equal to zero - $\Sigma P_{j_2} = 0$ and $\Sigma M_{j_2} = 0$
- Resultant centrifugal forces and their moments to be equal to zero -
 $\Sigma P_R = 0$ and $\Sigma M_{PR} = 0$

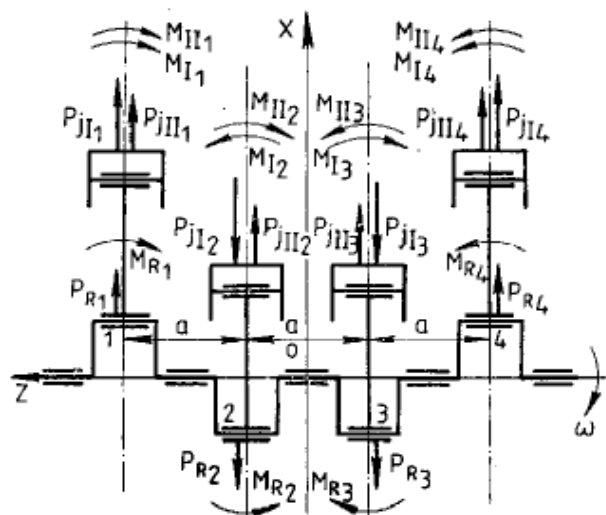

The amount of all inertia forces of first order is equal to zero:

$$\Sigma P_{j_1} = P_{j_{11}} + P_{j_{12}} + P_{j_{13}} + P_{j_{14}} = K \cdot \cos \varphi + K \cdot \cos(\varphi + 180^\circ) + K \cdot \cos(\varphi + 180^\circ) + K \cdot \cos \varphi = 0$$

$$\Sigma P_{j_1} = 0$$

The inertia forces of the second order have equal angles and the same direction:

$$\begin{aligned}\Sigma P_{j_2} &= P_{j_{21}} + P_{j_{22}} + P_{j_{23}} + P_{j_{24}} = K.\lambda.\cos 2\varphi + K.\lambda.\cos 2(\varphi + 180^\circ) + K.\lambda.\cos 2(\varphi + 180^\circ) + K.\lambda.\cos 2\varphi = \\ &= 4.K.\lambda.\cos 2\varphi\end{aligned}$$

$$\Sigma P_{j_2} = 4.K.\lambda.\cos 2\varphi$$

ΣP_{j_2} - can be balanced only if there are two counterweights placed on two additional shafts. In most engines ΣP_{j_2} is not balanced.

Centrifugal forces also are in equilibrium condition:

$$\Sigma P_R = P_{R1} + P_{R2} + P_{R3} + P_{R4} = -m_R.R.\omega^2 + m_R.R.\omega^2 + m_R.R.\omega^2 - m_R.R.\omega^2 = 0$$

$$\Sigma P_R = 0$$

Due to the symmetry of the shaft the momentums of the forces P_{j_1} , P_{j_2} and P_R are mutually balanced. Therefore

$$M_{j_1} = 0; M_{j_2} = 0; M_{PR} = 0$$

7.6. Flywheel

The total torque is a periodic function with period θ that causes angular velocity inequality of the crankshaft. To provide the necessary equability the flywheel with a mass is placed on the crankshaft. To be determined the flywheel mass, the acceptable level of fluctuation of angular velocity δ is used. For an automobile engine it is in range $\delta = (0,01 \div 0,02)$. In our case $\delta = 0,015$;

Excess kinetic energy can be determined in the following way:

$$L_{u31} = F_1 \cdot \mu_M \cdot \mu_\varphi, MJ$$

μ_M - Magnitude of the moment

μ_φ - Magnitude of the angle

Moment of inertial of the rotating engine parts is given by the expression:

$$J_0 = \frac{10^6}{\delta \cdot \omega^2} \cdot L_{u3n}$$

Moment of inertia of the flywheel J_M is usually accepted as $J_M = (0,8 \div 0,9) J_0$

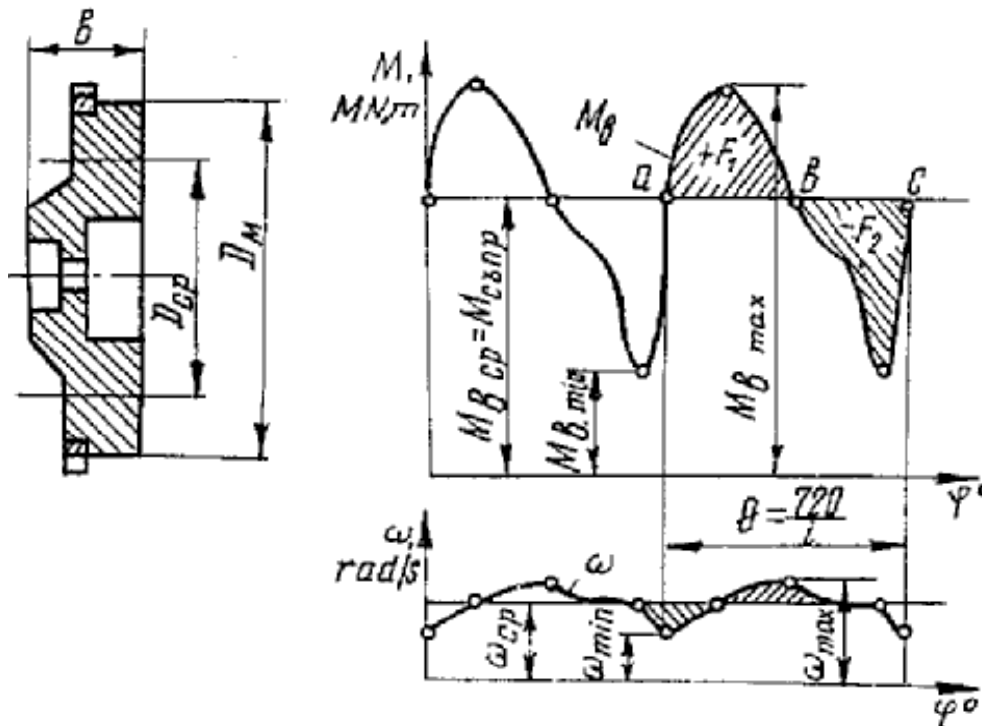

Fluctuation of the torque and angular velocity

Fly time of flywheel is given by the following expression:

$$m_M \cdot D_{cp}^2 = 4 \cdot J_M, \text{kg} \cdot \text{m}^2$$

Where: D_{cp}, m - average diameter of the flywheel, which is typically within

$$D_{cp} = (2 \div 3) \cdot S, \text{ we take } D_{cp} = 2,5 \cdot S = 3,0,064 = 0,192m$$

$S = 0,064m$ - motion of the piston

The mass of the flywheel is given by the expression:

$$m_M = \frac{4 \cdot J_M}{D_{cp}^2} = \frac{4 \cdot J_M}{0,192^2}$$

Outer diameter of the flywheel is determined:

$$D_M = \frac{60}{\pi \cdot n} \cdot V_{nep} = \frac{60}{3,14 \cdot 6000} \cdot 82 = 0,261m$$

where: $V_{nep} = (50 \div 100)m/s$ peripheral speed of steel flywheel

8. Calculation of the engine block and crankcase

In most car engines upper crankcase is made with the cylinder block and is called block-crankcase. During engine operation it bears large, dynamic and thermal loads. Strength calculation of block-crankcase is a difficult task due to its complicated configuration.

The thickness of the partitions and space cooling of cast iron blocks is $(4 \div 7)mm$, the ribs and sides of the upper crankcase are $(5 \div 8)mm$.

The compactness of the engine is determined by the expression $\frac{L_0}{D}$, where

$L_0 = 103mm$ is the distance between the axes of two adjacent cylinders and D the diameter of the cylinder.

$$\frac{L_0}{D} = \frac{103}{81} = 1,27$$

8.1. Cylinders

Tensile stress in the formation of the cylinder is determined by the formula for calculation of the cylindrical pressure vessels, without taking into account variability of distribution of stress in the wall thickness

$$\sigma_{on} = 0,5 \cdot p_z \cdot \frac{D}{\delta} \leq \sigma_{on}^{\delta on}$$

where:

$p_z = 8,839MPa$ - maximum gas pressure

$\delta = 0,008m$ - thickness of the cylinder

$D = 0,081m$ - diameter of the cylinder

$\sigma_{on}^{\delta on} = 60MPa$ - allowable tensile stress for cast iron cylinder sleeves

$$\sigma_{on} = 0,5 \cdot p_z \cdot \frac{D}{\delta} = 0,5 \cdot 8,839 \cdot \frac{0,081}{0,008} = 44,75MPa < 60MPa = \sigma_{on}^{\delta on}$$

Under the effect of the heating of the outer and inner surface of the cylinder sleeves emerge temperature stress, that can be calculated by the formula

$$\sigma_t = \frac{\alpha \cdot E \cdot \Delta T}{(1 - \mu) \cdot 2}, MPa$$

where: $\alpha = 11 \cdot 10^{-6} K^{-1}$ - coefficient of linear expansion of cast iron

$E = 1,0 \cdot 10^5 MPa$ - modulus of linear deformation of cast iron

$\Delta T = 100K$ - temperature difference between inner and outer wall of the cylinder sleeve

$\mu = 0,25$ - coefficient of Poisson

$$\sigma_t = \frac{11 \cdot 10^{-6} \cdot 1,0 \cdot 10^5 \cdot 100}{(1 - 0,27) \cdot 2} = 75,34 MPa$$

Aggregate pressure caused by the thermal load and gas pressure is equal to:

$$\sigma_{\Sigma} = \sigma_{on} + \sigma_t = 44,75 + 75,34 = 120,09 MPa < \sigma_{\Sigma}^{don} = 130 MPa$$

8.2. Cylinder Head

Cylinder head is mechanically loaded by the maximum gas pressure, by the force of pre-tightening of strength bolts in the place of attachment and as well as by the temperature difference that arise in it. Its complex shape and design does not allow to define exactly the loads and caused by them strain and stress, so the dimension of the walls of the cylinder heads will be taken from existing engines.

Height

$$H_c = (0,95 \div 1,20) \cdot D$$

The thickness δ_2 of the lower support wall and the thickness δ_p of cooler area of aluminum cylinder heads for a bore in the following range $D = (80 \div 150)mm$ is:

$$\delta_2 = 0,09 \cdot D + 2 = 0,09 \cdot 81 + 2 = 9,29 mm$$

$$\delta_p = 0,03 \cdot D + 4,2 = 0,03 \cdot 81 + 4,2 = 6,63 mm$$

The minimum distance between the walls of the cooler must be not less than 10mm and the thickness of wall channels should not be less than 5mm . The shape of the combustion chamber should be compact. Compactness is determined by the ratio of the surface of the combustion chamber F_k to its volume V_k . As the ratio is less, the loss in the coolant will be smaller.

8.3. Strength Stud bolts

Strength stud bolts are loaded in tension by pre-tightening force P_{np} , maximum gas force P_g and the force P_t caused by the heat of the engine due to different temperatures and different expansion rates of the block, head and pin.

Clamping studs must provide density between the cylinder and the cylinder head for all modes of operation. The calculation of power studs is limited to determine the following aspects:

- force generates by pre-tightening;
- Aggregate effort and the corresponding maximum stress pressure in the stud of heated engine;
- Safety factor

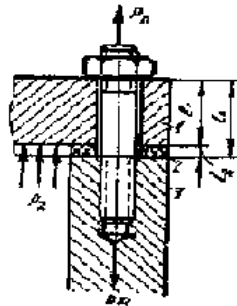

Scheme of connection of the cylinder head and block-crankcase

When an engine is inoperative the power studs are loaded by the force generated by pre-tightening P_n , which can be determined by the dependence:

$$P_n = m \cdot (1 - \chi) \cdot P_{z, \max}'' , MN$$

where:

$m = 4$ - safety coefficient of tightening the stud in presence of sealing gasket

$\chi = (0,15 \div 0,25)$ - coefficient of primary factor loading of bolting

$P_{z,\max}'' = p_{z,\max} \cdot \frac{F_k}{i}, MN$ - the force caused by the pressure of burning

$p_{z,\max} = 8,839 MPa$ - maximum gas pressure caused by the combustion in the cylinder

$i = 4$ - number of stud bolts for a cylinder

$F_k = (1,1 \div 1,3) \cdot F_\delta, m^2$ - projection area of the surface of the combustion chamber in a plane perpendicular to the axis of the cylinder

Accept: $F_k = 1,1 F_\delta$

$$F_\delta = \frac{\pi \cdot D^2}{4} = \frac{3,14 (81 \cdot 10^{-3})^2}{4} = 0,0052 m^2 \text{ - area of the piston}$$

$$F_k = 1,1 \cdot 0,0052 = 0,00572 m^2$$

$$P_{z,\max}'' = 8,839 \cdot \frac{0,00572}{4} = 0,0126 MN$$

$$P_n = 4 \cdot (1 - 0,15) \cdot 0,0126 = 0,0429 MN$$

A force of pre-tightening will cause extension of the stud and deformation of the clamping parts. When engine is operating the gas pressure will cause a further extension of the stud, increasing the deformation in the cylinder head and reduce deformation of the gasket.

Maximum force of tension can be determined by:

$$P_{on,\max} = m \cdot (1 + \chi) \cdot P_{z,\max}'' + P_{z,\max}'' \cdot \chi = 4 \cdot (1 + 0,15) \cdot 0,0126 + 0,0126 \cdot 0,15 = 0,0597 MN$$

Minimum force of tension is determined by:

$$P_{z,\min} = m \cdot (1 + \chi) \cdot P_{z,\max}'' = 4 \cdot (1 + 0,15) \cdot 0,0126 = 0,0579 MN$$

I choose steel having the following characteristics:

$\sigma_B = 1500 MPa$ - destruction limit

$\sigma_S = 1500 MPa$ - yield limit

$\sigma_{-1p} = 700MPa$ - fatigue of steel for tension and compression

$\alpha_\sigma = 0,3$ - factor of bringing asymmetrical cycle to equally dangerous symmetrical cycle at normal stress

$$\beta_\sigma = \frac{\sigma_{-1p}}{\sigma_s} = \frac{700}{1500} = 0,41 \text{ - quality factor of the area}$$

$K_\sigma = 3$ - concentration factor of stress

$\varepsilon'_\sigma = 0,8$ - scale factor, taking into account the influence of absolute dimensions of parts to the calculation of the fatigue limit

$\varepsilon''_\sigma = 0,6$ - technological factor, taking into account the state influence of the surface of the parts on the limits of endurance

9. Calculation of piston group

9.1. Piston

In the design of the piston, it is used parameters of already existing engines as elements are calculated strength, without taking into account variable methods of loads.

The main structural dimensions of a piston shall be adopted within:

Thickness of piston crown δ

$$(0,05 \div 0,10).D \quad \delta = 7mm$$

Height of the piston H

$$(0,8 \div 1,3).D \quad H = 75mm$$

Distance from the front to the axis of piston pin h_1

$$(0,45 \div 0,47).D \quad h_1 = 38mm$$

Diameter of thickening of piston pin d

$$(0,3 \div 0,5).D \quad d = 38mm$$

Size b

$$(0,3 \div 0,5).D \quad b = 33mm$$

Wall thickness of leading part δ_g

$$(1,5 \div 4,5)mm \quad \delta_g = 3mm$$

Thickness of the sealing part s

$$(0,03 \div 0,8).D \quad s = 3mm$$

Distance from the front to the first channel e

$$(0,06 \div 0,12).D \quad e = 7mm$$

Wall thickness between channels h_n

$$(0,03 \div 0,05).D \quad h_n = 3.5mm$$

Number of oil holes n_M

$$6 \div 12 \quad n_M = 8$$

Diameter holes for oil d_M

$$(0,03 \div 0,05).d_g \quad d_M = 1.5mm$$

Hole diameter of piston pin d_o

$$(0,22 \div 0,28).D \quad d_o = 23mm$$

Height of the leading part h_g

$$(0,6 \div 0,8).D \quad h_g = 55mm$$

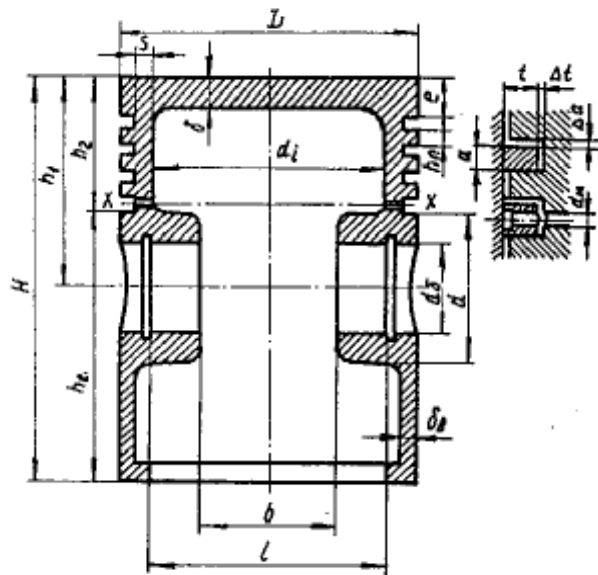

9.1.1. Tension pressure

$$\sigma_{oz} = \frac{M_{oz}}{W_{oz}} = p_{z,\max} \left(\frac{r_i}{\delta} \right)^2 \leq \sigma_{oz}^{\text{don}}, \text{MPa}$$

$$r_i = \left[\frac{D}{2} - (s + t + \Delta t) \right] = \left[\frac{0,081}{2} - (0,007 + 0,005 + 0,0008) \right] = 0,0277 \text{m} - \text{inner radius}$$

of the piston crown ;

$D = 0,081 \text{m}$ - diameter of the piston

$s = 0,007 \text{m}$ - thickness of the sealing part

$t = 0,005 \text{m}$ - radial thickness of the piston rings

$\Delta t = 0,0008 \text{m}$ - radial clearance between the piston ring and the channel

$\delta = 0,007 \text{m}$ - thickness of the crown

$p_{z,\max} = 8,839 \text{MPa}$ - maximum gas pressure

$\sigma_{oz}^{\text{don}} = 150 \text{MPa}$ - allowable bending of piston crown

$M_{oz} = \frac{1}{3} \cdot p_{z,\max} \cdot r_i^3, \text{MN.m}$ - moment of bending

$W_{oz} = \frac{1}{3} \cdot r_i \cdot \delta^2, \text{m}^3$ - moment of resistance

$$\sigma_{oz} = p_{z,\max} \cdot \left(\frac{r_i}{\delta} \right)^2 = 8,839 \cdot \left(\frac{0,0277}{0,007} \right)^2 = 138,41 \text{MPa} < \sigma_{oz}^{\text{don}} = 150 \text{MPa}$$

The leading part of the piston in a section $x-x$ is weakened due to oil outlet, so the tension and compression has to be checked

$$\sigma_H = \frac{P_{z,\max}}{F_{x-x}} \leq \sigma_H^{\text{don}}, \text{MPa}$$

$P_{z,\max} = p_{z,\max} \cdot F_o = 8,839 \cdot 0,0052 = 0,0459 \text{MN}$ - maximum gas pressure acting on the piston crown;

$$\sigma_H^{\text{don}} = 40 \text{MPa} - \text{allowable compressive stress}$$

$$F_{x-x} = \frac{\pi}{4} \cdot (d_k^2 - d_i^2) - n_M \cdot F', \text{m}^2 - \text{section area } x-x$$

where:

$d_k = D - 2 \cdot (t + \Delta t) = 0,081 - 2 \cdot (0,005 + 0,0008) = 0,0694 \text{m}$ - internal diameter of the channel for oil ring

$$d_i = 2 \cdot r_i = 2 \cdot 0,0277 = 0,0554 \text{m} - \text{internal diameter of the piston crown}$$

$$F' = \frac{d_k - d_i}{2} \cdot d_M = \frac{0,0694 - 0,0554}{2} \cdot 0,002 = 0,000014 \text{m}^2 - \text{cross area section of the}$$

oil hole

$$n_M = 8 - \text{number of oil holes}$$

$$d_M = 0,0015 \text{m} - \text{diameter of oil holes}$$

$$F_{x-x} = \frac{\pi}{4} \cdot (d_k^2 - d_i^2) - n_M \cdot F' = \frac{3,14}{4} \cdot (0,0694^2 - 0,0554^2) - 8 \cdot 0,000014 = 0,00127 \text{m}^2$$

$$\sigma_H = \frac{P_{z,\max}}{F_{x-x}} = \frac{0,0459}{0,00127} = 36,2 \text{MPa} < \sigma_H^{\text{don}} = 40 \text{MPa}$$

9.1.2. Tension stress of the area $x-x$

$$\sigma_{on} = \frac{P_{j,\max}}{F_{x-x}} \leq \sigma_{on}^{\text{don}}, MPa$$

$P_{j,\max} = 10^{-6} \cdot m_{x-x} \cdot R \cdot \omega_{nx,\max}^2 \cdot (1 + \lambda), MN$ - inertia force of reciprocating motion of the mass of the piston in the section $x-x$, defined at maximum idling speed of the engine

$$n_{nx,\max} = (1,05 \div 1,35)n, \text{min}^{-1} \text{ - maximum speed of the crankshaft at idle}$$

$$n_{nx,\max} = 1,1 \cdot 6000 = 6600 \text{min}^{-1}$$

$$\omega_{nx,\max} = \frac{\pi \cdot n_{nx,\max}}{30} = \frac{3,14 \cdot 6600}{30} = 690,8 \text{rad}^{-1}$$

$$\sigma_{on}^{\text{don}} = 10 \text{MPa} \text{ - allowable tensile stress}$$

$$m_{x-x} = (0,4 \div 0,6) \cdot m_{\sigma,ep}, \text{kg} \text{ - mass of the piston over the section } x-x$$

$$m_{\sigma,ep} = 0,703 \text{kg} \text{ - mass of the piston group}$$

$$m_{x-x} = 0,5 \cdot 0,703 = 0,352 \text{kg}$$

$$\lambda = \frac{R}{L_M} = \frac{0,032}{0,142} = 0,23 \text{ - ratio between the crank of the crankshaft } R \text{ and the}$$

connecting rod L_M

$$P_{j,\max} = 10^{-6} \cdot m_{x-x} \cdot R \cdot \omega_{nx,\max}^2 \cdot (1 + \lambda) = 10^{-6} \cdot 0,352 \cdot 0,032 \cdot (690,8)^2 \cdot (1 + 0,23) = 0,00661 \text{MN}$$

$$\sigma_{on} = \frac{P_{j,\max}}{F_{x-x}} = \frac{0,00661}{0,00127} = 5,21 \text{MPa} < \sigma_{on}^{\text{don}} = 10 \text{MPa}$$

The leading part of the piston with height h_g is checked on maximum specific pressure by:

$$q_g = \frac{N_{\max}}{h_g \cdot D}, \text{MPa}$$

$N_{\max} = 0,001859 \text{MN}$ - maximum regular force, when the engine is operating at maximum power

$$h_g = 0,055 \text{m} \text{ - height of the leading part of the piston}$$

$$\text{For existing engines } q_g = (0,30 \div 1,0) \text{MPa}$$

$$q_e = \frac{N_{\max}}{h_e \cdot D} = \frac{0,00367}{0,055 \cdot 0,081} = 0,824 \text{MPa}$$

For engines with high compression ratio , thickness of partition wall h_n is represented by ring plate with diameter:

$$d_k = D - 2 \cdot (t + \Delta t) = 0,081 - 2 \cdot (0,005 + 0,0008) = 0,0694 \text{m}$$

Load surface can be determined by:

$$F_{ck} = \frac{\pi}{4} \cdot (D^2 - d_k^2) = \frac{3,14}{4} \cdot (0,081^2 - 0,0694^2) = 0,00137 \text{m}^2$$

Tension bending:

$$\sigma_{oz} = 0,0045 \cdot p_{z,\max} \cdot \left(\frac{D}{h_n} \right)^2 = 0,0045 \cdot 8,839 \cdot \left(\frac{0,081}{0,0035} \right)^2 = 21,29 \text{MPa}$$

Shear (tension):

$$\tau_{cp} = 0,0314 \cdot p_{z,\max} \cdot \frac{D}{h_n} = 0,0314 \cdot 8,839 \cdot \frac{0,081}{0,0035} = 6,42 \text{MPa}$$

Sum voltage of the third strength theory is:

$$\sigma_{\Sigma} = \sqrt{\sigma_{or}^2 + 4 \cdot \tau_{cp}^2} = \sqrt{21,29^2 + 4 \cdot 6,42^2} = \sqrt{618,13} = 24,86 \text{MPa} < \sigma_{\Sigma}^{op} = 30 \text{MPa}$$

To avoid jamming of the piston in the cylinder when the engine is heated, we have to determine diameter D_y of sealing part and diameter D_B of leading part of the piston and hence a diametrical clearance sealing part Δ_y and leading part Δ_B of the piston, when the engine is cold.

For existing engines, the clearances in hot condition are in the following range:

$$\Delta'_y = (0,002 \div 0,003) D, \text{mm} \rightarrow \Delta'_y = 0,0025 \cdot 81 = 0,203 \text{mm}$$

$$\Delta'_e = (0,0005 \div 0,0015) D, \text{mm} \rightarrow \Delta'_e = 0,0015 \cdot 81 = 0,122 \text{mm}$$

Then:

$$D_y = \frac{D \cdot [1 + \alpha_u \cdot (T_y - T_0)] - \Delta'_y}{1 - \alpha_o \cdot (T_y - T_0)}, \text{m}$$

$$D_{\epsilon} = \frac{D \cdot [1 + \alpha_y \cdot (T_y - T_0)] - \Delta'_y}{1 + \alpha_{\epsilon} \cdot (T_{\epsilon} - T_0)}, m$$

where:

$\alpha_y = 11 \cdot 10^{-6} K^{-1}$ - coefficient of linear expansion of the material of the cylinder;

$\alpha_{\epsilon} = 11 \cdot 10^{-6} K^{-1}$ - coefficient of the linear expansion of the material of the

piston;

$T_y = 388K$ - temperature of the cylinder;

$T_y = 593K$ - temperature of the sealing part of the piston;

$T_{\epsilon} = 473K$ - temperature of the leading part of the piston;

$T_0 = 293K$ - temperature of the engine in cold condition;

$$D_y = \frac{D \cdot [1 + \alpha_y \cdot (T_y - T_0)] - \Delta'_y}{1 + \alpha_{\epsilon} \cdot (T_y - T_0)} = \frac{0,081 \cdot [1 + 11 \cdot 10^{-6} \cdot (388 - 293)] - 0,203 \cdot 10^{-3}}{1 + 11 \cdot 10^{-6} \cdot (593 - 293)} = 0,08061m$$

$$D_{\epsilon} = \frac{D \cdot [1 + \alpha_y \cdot (T_y - T_0)] - \Delta'_y}{1 + \alpha_{\epsilon} \cdot (T_{\epsilon} - T_0)} = \frac{0,081 \cdot [1 + 11 \cdot 10^{-6} \cdot (388 - 293)] - 0,122 \cdot 10^{-3}}{1 + 11 \cdot 10^{-6} \cdot (473 - 293)} = 0,08081m$$

The sealing part and the leading part of the engine in a cold condition will be:

$$\Delta_y = D - D_y = 81 - 80,61 = 0,39mm$$

$$\Delta_{\epsilon} = D - D_{\epsilon} = 81 - 80,81 = 0,19mm$$

9.2. Piston Pin

Piston pins are subject of varying in shape and size loading and that cause bending, shearing and surface tension pressure, so we choose steel as a material that they have been made.

Structural dimensions of the piston can be determined using existing engines:

Outer diameter of the bolt d_{ϵ}

$$(0,22 \div 0,28) \cdot D \quad d_{\epsilon} = 23mm$$

Inner diameter of the bolt d_g

$$(0,65 \div 0,75) \cdot d_g \quad d_g = 14mm$$

Length of the bolt l

$$(0,88 \div 0,93) \cdot D \quad l = 73mm$$

Length of the upper head of the rod l_M

$$(0,28 \div 0,38) \cdot D \quad l_M = 32mm$$

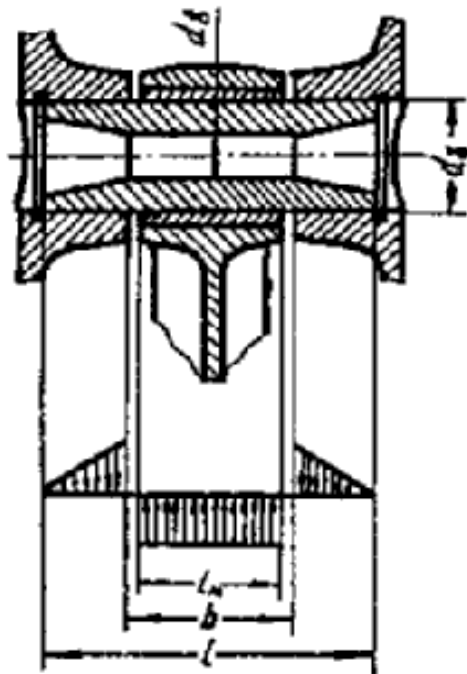

Schema of the piston pin

q_M - specific pressure in the upper head of the connecting rod

$$q_M = \frac{P_{z,\max} + P_{j,\max}}{d_g \cdot l_M} < q_M^{\text{don}}, MPa$$

q_{δ} - specific pressure in the holes of the piston

$$q_{\delta} = \frac{P_{z,\max} + K \cdot P_{j,\max}}{d_{\delta} \cdot (l - b)} < q_{\delta}^{\text{don}}, MPa$$

where:

$P_{z,\max} = 0,0459MN$ - maximum gas force acting on piston crown;

$$P_{j,\max} = -m_{\sigma,zp} \cdot \omega^2 \cdot R \cdot (1 + \lambda) \cdot 10^{-6} = 0,703 \cdot 628^2 \cdot 0,032 \cdot (1 + 0,23) \cdot 10^{-6} = 0,010912MN$$

Max force of inertia of the piston group;

$d_{\sigma} = 21mm$ - outer diameter of the piston pin

$l_M = 32mm$ - length of the upper head of the connecting rod

$l = 73mm$ - length of the piston pin

$b = 34mm$ - length between the piston pin holes

$K = (0,78 \div 0,86)$ - coefficient, taking into account the mass of the piston pin

$q_M^{\text{don}} = 70MPa$ - allowable specific pressure in the upper head of the connecting

rod

$q_{\sigma}^{\text{don}} = 50MPa$ - allowable specific pressure in the holes of the piston

$$q_M = \frac{0,0459 - 0,010912}{0,021 \cdot 0,024} = 68,76MPa < q_M^{\text{don}} = 70MPa$$

$$q_{\sigma} = \frac{0,0459 - 0,78 \cdot 0,010912}{0,021 \cdot (0,073 - 0,034)} = 45,65MPa < q_{\sigma}^{\text{don}} = 50MPa$$

The maximum load of the piston pin is the force, with which the bolt is pressed against the ear the piston;

$$P = P_{z,\max} + K \cdot P_{j,\max} = 0,0459 + 0,78 \cdot (-0,010912) = 0,0544MN$$

Bending stress of the bolt:

$$\sigma_{\sigma z} = \frac{P \cdot (l + 2 \cdot b - 1,5 \cdot l_M)}{1,2 \cdot d_{\sigma}^3 \cdot (1 - \alpha^4)} < \sigma_{\sigma z}^{\text{don}}, MPa$$

where:

$$\alpha = \frac{d_e}{d_{\sigma}} = \frac{14}{23} = 0,6$$

- the ratio between the inner and the outer diameter

$\sigma_{\sigma z}^{\text{don}} = 500MPa$ - allowable bending stress

$$\sigma_{\sigma z} = \frac{P \cdot (l + 2 \cdot b - 1,5 \cdot l_M)}{1,2 \cdot d_{\sigma}^3 \cdot (1 - \alpha^4)} = \frac{0,0544 \cdot (0,073 + 2 \cdot 0,034 - 1,5 \cdot 0,032)}{1,2 \cdot 0,021^3 \cdot (1 - 0,6^4)} = 486MPa < \sigma_{\sigma z}^{\text{don}}$$

The maximum tangential shear stress acting on the sections of the screw, located between the ears of the piston and connecting rod head is calculated by:

$$\tau_{cp} = \frac{0,85 \cdot (1 + \alpha + \alpha^2) \cdot P}{d_b^2 \cdot (1 - \alpha^4)} \leq \tau_{cp}^{\text{don}}, MPa$$

$$\tau_{cp}^{\text{don}} = 250 MPa - \text{allowable shear stress}$$

$$\tau_{cp} = \frac{0,85 \cdot (1 + \alpha + \alpha^2) \cdot P}{d_b^2 \cdot (1 - \alpha^4)} = \frac{0,85 \cdot (1 + 0,6 + 0,6^2) \cdot 0,0544}{0,021^2 \cdot (1 - 0,6^4)} = 210,47 MPa < \tau_{cp}^{\text{don}}$$

The surface of the piston pin is loaded unequally. It is assumed that it has a sinusoidal distribution law in result of which, when the engine is operating the elongation of the bolt is obtained. Maximum elongation $\Delta d_{\sigma, \max}$ or increasing of the piston pin diameter in a plane perpendicular to the plane of load occurs in the middle part of the bolt and is defined as:

$$\Delta d_{\sigma, \max} = \frac{0,09 \cdot P}{l \cdot E} \cdot \left(\frac{1 + \alpha}{1 - \alpha} \right)^3 \cdot k_1, m$$

where:

$$k_1 = 1,5 - 15 \cdot (\alpha - 0,4)^3 = 1,5 - 15 \cdot (0,6 - 0,4)^3 = 1,38 - \text{correction factor}$$

$$E = 2,3 \cdot 10^5 MPa - \text{module of a linear deformation of the steel}$$

$$\Delta d_{\sigma, \max} = \frac{0,09 \cdot P}{l \cdot E} \cdot \left(\frac{1 + \alpha}{1 - \alpha} \right)^3 \cdot k_1 = \frac{0,09 \cdot 0,0544}{0,073 \cdot 2,3 \cdot 10^5} \cdot \left(\frac{1 + 0,6}{1 - 0,6} \right)^3 \cdot 1,38 = 0,04 mm$$

Elongation maximum value should not be greater than:

$$\Delta d_{\sigma, \max} = (0,02 \div 0,05) mm.$$

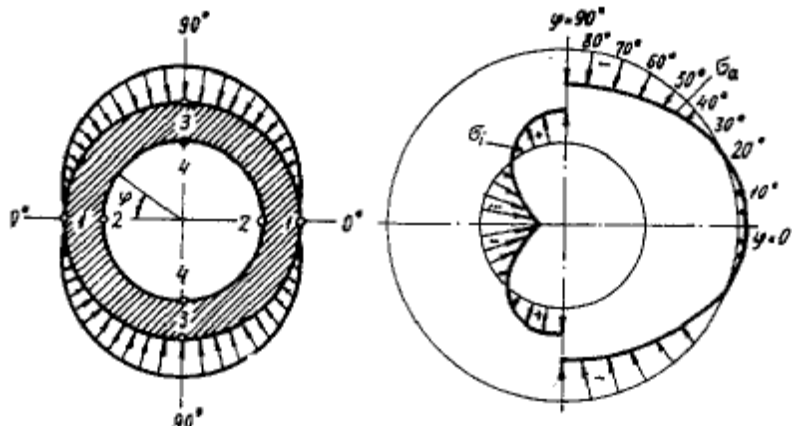

Schema of an elongation of the piston pin

I determine the bending stress as follow:

At an angle $\varphi = 0$:

At points 1:

$$\begin{aligned} \sigma_1 &= \frac{P}{l.d_6} \left[0,19 \cdot \frac{(2+\alpha) \cdot (1+\alpha)}{(1-\alpha)^2} - \frac{1}{1-\alpha} \right] \cdot k_1 = \\ &= \frac{0,0544}{0,073 \cdot 0,023} \left[0,19 \cdot \frac{(2+0,6)(1+0,6)}{(1-0,6)^2} - \frac{1}{1-0,6} \right] \cdot 1,38 = 109,1 \text{MPa} \end{aligned}$$

At points 2:

$$\begin{aligned} \sigma_2 &= -\frac{P}{l.d_6} \left[0,19 \cdot \frac{(1+2\alpha) \cdot (1+\alpha)}{(1-\alpha)^2 \cdot \alpha} + \frac{1}{1-\alpha} \right] \cdot k_1 = \\ &= -\frac{0,0544}{0,073 \cdot 0,023} \left[0,19 \cdot \frac{(1+2 \cdot 0,6)(1+0,6)}{(1-0,6)^2 \cdot 0,6} + \frac{1}{1-0,6} \right] \cdot 1,38 = -423,16 \text{MPa} \end{aligned}$$

At an angle $\varphi = 90$:

At points 3:

$$\begin{aligned} \sigma_3 &= -\frac{P}{l.d_6} \left[0,174 \cdot \frac{(2+\alpha) \cdot (1+\alpha)}{(1-\alpha)^2} + \frac{0,636}{1-\alpha} \right] \cdot k_1 = \\ &= -\frac{0,0544}{0,073 \cdot 0,023} \left[0,174 \cdot \frac{(2+0,6)(1+0,6)}{(1-0,6)^2} + \frac{0,636}{1-0,6} \right] \cdot 1,38 = -131,14 \text{MPa} \end{aligned}$$

At points 4:

$$\sigma_4 = \frac{P}{l \cdot d_\sigma} \cdot \left[0,174 \cdot \frac{(1+2\alpha) \cdot (1+\alpha)}{(1-\alpha)^2 \cdot \alpha} - \frac{0,636}{1-\alpha} \right] \cdot k_1 =$$

$$= \frac{0,0544}{0,073 \cdot 0,023} \cdot \left[0,174 \cdot \frac{(1+2 \cdot 0,6)(1+0,6)}{(1-0,6)^2 \cdot 0,6} - \frac{0,636}{1-0,6} \right] \cdot 1,38 = 265,96 MPa$$

The biggest bending stress caused by elongation occurs at an inner surface of the bolt at points 2; The bending stress should not exceed 450MPa .

Working clearance in a hot state of the compound “piston pin – piston” must be:

$$\Delta L = 0,001 \cdot d_\sigma = 0,001 \cdot 23 = 0,023 mm$$

Mounting clearance Δ_σ of the compound is different from the working clearance ΔL and is determined by:

$$\Delta_\sigma = \Delta L + [\alpha_\sigma(T_\sigma - T_0) - \alpha_{\sigma\sigma}(T_{\sigma\sigma} - T_0)]d, mm$$

where:

$$\alpha_{\sigma\sigma} = 11 \cdot 10^{-6} K^{-1} - \text{coefficient of linear expansion of the steel}$$

$$\alpha_\sigma = 25 \cdot 10^{-6} K^{-1} - \text{coefficient of linear expansion of the aluminum allows}$$

$$T_{\sigma\sigma} = T_\sigma = 390 K - \text{temperature of the piston pin and piston}$$

$$T_0 = 293 K - \text{mounting temperature}$$

$$\Delta_\sigma = 0,023 + [23 \cdot 10^{-6} \cdot (390 - 293) - 11 \cdot 10^{-6} \cdot (390 - 293)] \cdot 23 = 0,049 mm$$

For existing engines mounting clearance for pistons of aluminum allows is within:
 $0,2 \div 0,5 mm$

9.3. Piston rings

Piston rings provide a tight of the cylinder space. They work at high temperature, so they must have high elasticity, strength, durability and low coefficient of friction with the cylinder walls. Materials for their manufacture are iron with chromium, nickel, copper, titanium and others.

The main structural dimensions of the piston rings can be adopted according to existing engines:

Radial thickness of the grommet t_y

$$(0,039 \div 0,045) \cdot D \quad t_y = 3,5 mm$$

Radial thickness of the oil collecting ring t_M

$$(0,038 \div 0,043).D \quad t_M = 3.5mm$$

Height of the ring a

$$(2 \div 4)mm \quad a = 3mm$$

Radial clearance of the grummet Δt_y

$$(0,50 \div 0,95)mm \quad \Delta t_y = 0,8mm$$

Radial clearance of the oil collecting ring Δt_M

$$(0,50 \div 0,95)mm \quad \Delta t_M = 0,8mm$$

Axial clearance of the ring Δa

$$(0,04 \div 0,08)mm \quad \Delta a = 0,06mm$$

Clearance in the slot of the ring at Free State A_0

$$(2,4 \div 4,0).t \quad A_0 = 12mm$$

9.3.1. Determination of the average radial pressure on the cylinder walls caused by the ring

$$p_{cp} = 0,152.E \cdot \frac{\frac{A_0}{t}}{\left(\frac{D}{t} - 1\right)^3 \cdot \frac{D}{t}}, MPa$$

where:

$E = 1.10^5 MPa$ - module of linear deformation of cast iron

$D = 0,081m$ - diameter of the cylinder

$A_0 = 0,0096m$ - clearance in the slot of the ring a free state

$t = 0,0035m$ - radial thickness of the ring

$$p_{cp} = 0,152.E \cdot \frac{A_0}{\left(\frac{D}{t}-1\right)^3 \cdot \frac{D}{t}} = 0,152 \cdot 1 \cdot 10^5 \cdot \frac{0,012}{\left(\frac{0,081}{0,0035}-1\right)^3 \cdot \frac{0,081}{0,0035}} = 0,207 MPa$$

The average radial pressure must be within the following limits:

$$p_{cp} = (0,11 \div 0,37), MPa \text{ - for the grummet}$$

$$p_{cp} = (0,20 \div 0,40), MPa \text{ - for the oil collecting rings}$$

9.3.2. Determination of bending stress in the piston rings

- Working condition:

$$\sigma_{\sigma_{z,pc}} = 2,61 \cdot p_{cp} \cdot \left(\frac{D}{t}-1\right)^2 = 2,61 \cdot 0,207 \cdot \left(\frac{0,081}{0,0035}-1\right)^2 = 264,8 MPa$$

- placing the ring on the piston:

$$\sigma_{\sigma_{z,n}} = \frac{4.E \cdot \left(1 - 0,114 \cdot \frac{A_0}{t}\right)}{m \cdot \left(\frac{D}{t}-1,4\right)^2} = \frac{4 \cdot 1 \cdot 10^5 \cdot \left(1 - 0,114 \cdot \frac{0,0012}{0,0035}\right)}{2 \cdot \left(\frac{0,081}{0,0035}-1,4\right)^2} = 406,6 MPa$$

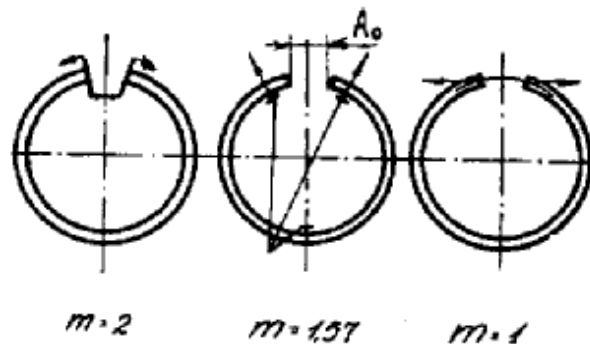

Ring opening when inserting the piston

$m = 2$ - coefficient depending on the way of ring opening

$\sigma_{\sigma_{z,n}}^{don} = 450 MPa$ - allowable bending stress coefficient

Minimum working clearance in the key of the piston ring in hot state should be $\Delta' = (0,06 \div 0,10), mm$, as far as mounting clearance is considered it can be determined by:

$$\Delta = \Delta' + \pi \cdot D \cdot [\alpha_{np}(T_{np} - T_0) - \alpha_y(T_y - T_0)] mm$$

where:

$\alpha_{np} = 10,2 \cdot 10^{-6} K^{-1}$ - temperature coefficient of linear expansion of the material of the ring

$\alpha_y = 10 \cdot 10^{-6} K^{-1}$ - temperature coefficient of linear expansion of the material of the cylinder

$T_{np} = 520 K^{-1}$ - temperature of the ring in working condition

$T_y = 388 K$ - temperature of the cylinder in working condition

$T_0 = 293 K$ - mounting temperature

$$\Delta = 0,08 + 3,14 \cdot 81 \cdot [10,2 \cdot 10^{-6} \cdot (520 - 293) - 10 \cdot 10^{-6} \cdot (388 - 293)] = 0,427 mm$$

10. Calculation of the connecting rod

When the engine is running, the connection rod is subjected to varying in size and direction gas and inertia forces. This is the reason why it is made by stainless steel with high resistance to fatigue.

For my connecting rod I choose steel with the following parameters:

$$\sigma_B = 1700MPa \text{ - limit destruction of the steel;}$$

$$\sigma_S = 1600MPa \text{ - yield strength;}$$

$$\sigma_{-1p} = 700MPa \text{ - fatigue limit for tension and compression;}$$

$$\beta_\sigma = \frac{\sigma_{-1p}}{\sigma_S} = \frac{700}{1600} = 0,41 \text{ - quality rate of the surface;}$$

$K_\sigma = 1,2 + 1,8 \cdot 10^{-4} \cdot (\sigma_B - 400) = 1,2 + 1,8 \cdot 10^{-4} \cdot (1700 - 400) = 1,434$ - concentration factor of stress;

$\varepsilon_\sigma'' = 0,8$ - technology factor takes into account the influence of state of the surface of the parts on the limits of fatigue;

Connecting rod consists of upper head, trunk, lower head and connecting rod bolts. The dimensions of the rod can be determined according to already existing engines.

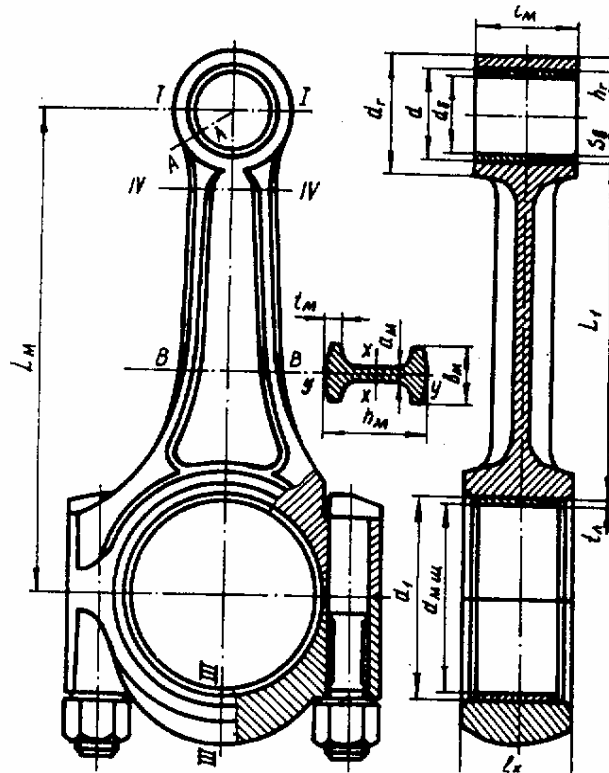

Connecting Rod

Inner diameter of the upper head without sleeve d

$$d = d_6 \quad d = 23mm$$

Outer diameter of the upper head d_2

$$d_2 = (1,25 \div 1,65)d_6 \quad d_2 = 36mm$$

Length of the upper head l_M

$$l_M = (0,33 \div 0,45)D \quad l_M = 32mm$$

Minimal radial thickness of the upper head h_2

$$h_2 = (0,16 \div 0,27)d_6 \quad h_2 = 5mm$$

Minimal height of the profile $h_{M,min}$

$$h_{M,\min} = (0,50 \div 0,55)d_2 \quad h_{M,\min} = 16mm$$

Dimensions:

$$\begin{aligned} h_M &= (1,2 \div 1,4)h_{M,\min} & h_M &= 22mm \\ b_M &= (0,50 \div 0,60)l_M & b_M &= 18mm \\ a_M &\approx t_M & a_M &= 5mm \end{aligned}$$

Diameter of the connecting rod neck d_{mu}

$$d_{mu} = (0,56 \div 0,75).D \quad d_{mu} = 47mm$$

Thickness of the bearing shells t_{fl}

$$t_{fl} = (0,03 \div 0,05)d_{mu} \quad t_{fl} = 2mm$$

Distance between connecting rod bolts C

$$C = (1,30 \div 1,75)d_{mu} \quad C = 86mm$$

Length of the low head l_k

$$l_k = (0,45 \div 0,95)d_{mu} \quad l_k = 30mm$$

10.1. Upper head of the connecting rod

I calculate the tension in cross section area I – I . The upper head is loaded by variable gas and inertia force and also by the constant force of pressing the piston pin in it. The maximum tensile force at the head of the rod occurs when the piston is in UDP at the beginning of intake stroke at a maximum speed of crankshaft of the engine idling. At this point the gas force is very small and can be ignored. The maximum inertia force create by the mass of the piston group and the mass of the upper head in cross section I – I will be:

$$P_{j,\max} = 10^{-6} \cdot (m_{\sigma,zp} + m_{zM}) R \cdot \omega_{nX,\max}^2 \cdot (1 + \lambda), MN$$

where:

$$m_{\sigma,zp} = 0,703kg \text{ - the mass of the piston group}$$

$m_{2M} = 0,07.m_M = 0,07.0,661 = 0,0462kg$ - the mass of the upper head above section I – I

$m_M = 0,661kg$ - the mass of the connecting rod

$\omega_{nx,max} = \frac{\pi.n_{nx,max}}{30} = \frac{\pi.6000}{30} = 628rad^{-1}$ - maximum angular velocity of the crankshaft at idling

$$P_{j,max} = 10^{-6} \cdot (m_{\sigma,zp} + m_{2M}) \cdot R \cdot \omega_{nx,max}^2 \cdot (1 + \lambda) = 10^{-6} \cdot (0,703 + 0,0462) \cdot 0,032 \cdot 628^2 \cdot (1 + 0,23) = 0,0116MN$$

Maximum tensile stress in section I – I is:

$$\sigma_{on,max} = \frac{P_{j,max}}{2 \cdot h_{z,min} \cdot l_M} = \frac{0,0116}{2 \cdot 0,005 \cdot 0,032} = 36,25MPa$$

When $P_j > 0$ the inertia force acts to the crankshaft and do not load the section. For that reason the minimum tensile stress will be $\sigma_{on,min} = 0$

Tensions in the upper head of the rod are caused by pressing the piston pin and by the different coefficient of linear expansion of the piston pin and heated head. They will depend on the total tightness Δ_Σ :

$$\Delta_\Sigma = \Delta + \Delta_t, mm$$

where:

$\Delta = 0,07mm$ - tightness obtained by pressing the piston pin

$\Delta_t = d \cdot (\alpha_{\sigma\sigma} - \alpha_M) \cdot \Delta T, mm$ - tightness obtained by the different linear expansion at heating

$d = 23mm$ - inner diameter of the head

$\alpha_{\sigma\sigma} = 11 \cdot 10^{-6} K^{-1}$ and $\alpha_M = 11 \cdot 10^{-6} K^{-1}$ are coefficient of linear expansion of the piston pin and the rod

$\Delta T = 100K$ - heating temperature of the head and the sleeve at work

$$\Delta_t = d \cdot (\alpha_{\sigma\sigma} - \alpha_M) \cdot \Delta T = 23 \cdot (18 - 10) \cdot 10^{-6} \cdot 100 = 0,0184mm$$

$$\Delta_\Sigma = \Delta + \Delta_t = 0,07 + 0,0184 = 0,0884mm$$

The specific surface pressure of contact will be:

$$p = \frac{\Delta_{\Sigma}}{d \cdot \left(\frac{\frac{d_e^2 + d^2}{d_e^2 - d^2} + \mu}{E_m} + \frac{\frac{d^2 + d_o^2}{d^2 - d_o^2} - \mu}{E_o} \right)} = \frac{0,0884}{23 \cdot \left(\frac{\frac{36^2 + 23^2}{36^2 - 23^2} + 0,3}{2,2 \cdot 10^5} + \frac{\frac{23^2 + 14^2}{23^2 - 14^2} - 0,3}{1,15 \cdot 10^5} \right)} = 37,9 \text{ MPa}$$

where:

$\mu = 0,3$ - coefficient of Poisson;

$E_m = 2,2 \cdot 10^5 \text{ MPa}$, $E_o = 1,15 \cdot 10^5 \text{ MPa}$ - module of linear deformation of the steel;

Once we know the specific pressure of the total tightness in Lamé formula, we can determine the stresses and that occurs in the outer and inner surface of the head:

Stresses in the outer surface are:

$$\sigma'_a = p \cdot \frac{2 \cdot d^2}{d_o^2 - d^2} = 37,9 \cdot \frac{2 \cdot 23^2}{36^2 - 23^2} = 51,92 \text{ MPa} < \sigma_a^{\text{don}} = 100 \text{ MPa}$$

Stresses in the inner surface are:

$$\sigma'_i = p \cdot \frac{d_e^2 + d^2}{d_e^2 - d^2} = 37,9 \cdot \frac{36^2 + 23^2}{36^2 - 23^2} = 90,2 \text{ MPa} < \sigma_i^{\text{don}} = 100 \text{ MPa}$$

10.2. Stem of the connecting rod

The stem of the rod is loaded strength by inertia forces of reciprocating masses above the issue section. It is also loaded by gas pressure force and longitudinal bending of total gas and inertia force.

Compressive force P_H will have maximum value at TDP :

$$P_H = p_{z,\text{max}} \cdot F_o + P_j, \text{ MN}$$

where:

$p_{z,\text{max}} = 8,839 \text{ MPa}$ - the maximum gas pressure in the cylinder;

$F_o = 0,0058 \text{ m}^2$ - the area of the piston;

$P_j = -10^{-6} \cdot (m_{o,2p} + m_{m,c}) R \omega^2 (1 + \lambda), \text{ MN}$ - the inertia force

$m_{\delta, ep} = 0,703kg$ - mass of the piston group;

$m_{mc} = 0,176kg$ - the mass of the rod lying above the section;

$$P_j = -10^{-6} \cdot (0,703 + 0,176) \cdot 0,032 \cdot 628^2 \cdot (1 + 0,23) = -0,0137MN$$

$$P_u = p_{z, \max} \cdot F_{\delta} + P_j = 8,839 \cdot 0,0058 + (-0,0137) = 0,0376MN$$

Maximum tensile force P_{on} will occur at the start of filling. At this point the inertia force will be negligible small so:

$$P_{on} = P_j = -0,0137MN$$

Dangerous for the stem is a secondary section B-B, which is calculated on stress of pressure and longitudinal bending in two planes: the plane of oscillation of the rod when the stem is regarded as case of attachment of two joints and the plane perpendicular to the plane of oscillation as a case of hesitation on both ends.

Aggregate voltages are determined by the Nove-Rankin formula:

- to the plane of oscillation:

$$\sigma_1 = K_x \cdot \frac{P_u}{f_{cp}}, MPa$$

- to the plane, perpendicular to the oscillation` plane

$$\sigma_2 = K_y \cdot \frac{P_u}{f_{cp}}, MPa$$

where:

$K_x = 1,10$ - factor considering the influence of longitudinal bending plane of oscillation;

f_{cp}, m^2 - area of the middle section of the stem;

$$f_{cp} = h_M \cdot b_M - (b_M - a_M) \cdot (h_M - 2t_M) = 0,022 \cdot 0,018 - (0,018 - 0,005) \cdot (0,022 - 2 \cdot 0,005) = 0,00024m^2$$

$$\sigma_1 = K_x \cdot \frac{P_u}{f_{cp}} = 1,1 \cdot \frac{0,0376}{0,00024} = 172,3MPa < \sigma_{don} = 200MPa$$

$$\sigma_2 = \sigma_1 = 172,3 \text{MPa} < \sigma_{oon} = 200 \text{MPa}$$

Tensile stress in the middle section B-B;

$$\sigma_{on} = \frac{P_{on}}{f_{cp}} = \frac{-0,0137}{0,00024} = -57,1 \text{MPa}$$

Tensions in the stem are changed in the asymmetrical cycle in which the amplitude and the average voltage will be:

$$\sigma_{a1} = \frac{\sigma_1 - \sigma_{on}}{2} = \frac{172,3 - (-57,1)}{2} = 114,7 \text{MPa}$$

$$\sigma_{m1} = \frac{\sigma_1 + \sigma_{on}}{2} = \frac{172,3 + (-57,1)}{2} = 57,6 \text{MPa}$$

$$\sigma_{ak1} = \frac{K_{\sigma}}{\varepsilon_{\sigma}} \cdot \sigma_{a1} = \frac{1,434}{0,80,8} \cdot 114,7 = 256,9 \text{MPa}$$

$$n_x = n_y = \frac{\sigma_{-1p}}{\sigma_{ak1} + \alpha_{\sigma} \cdot \sigma_{m1}} = \frac{700}{114,7 + 0,357,6} = 5,3$$

The minimum section IV – IV is very important, and because of this it should be checked in tension and compression by the formula:

$$\sigma'_{on} = \frac{P_{on}}{f_{\min}}, \text{MPa}$$

$$\sigma'_H = \frac{P_H}{f_{\min}}, \text{MPa}$$

$$f_{\min} = h_{M,\min} \cdot b_{M,\min} - (b_{M,\min} - a_M) \cdot (h_{M,\min} - 2 \cdot t_M) = 0,02 \cdot 0,015 - (0,015 - 0,005) \cdot (0,02 - 2 \cdot 0,005) = 0,0002 \text{m}^2$$

$$\sigma'_{on} = \frac{P_{on}}{f_{\min}} = \frac{-0,0137}{0,0002} = -68,5 \text{MPa}$$

$$\sigma'_H = \frac{P_H}{f_{\min}} = \frac{0,0376}{0,0002} = 188 \text{MPa}$$

In determining the safety factor of the section IV – IV, σ'_{on} is taken with sign “-“

$$\sigma_a = \frac{\sigma'_H - \sigma'_{on}}{2} = \frac{188 - (-68,5)}{2} = 128,3 MPa$$

$$\sigma_m = \frac{\sigma'_H + \sigma'_{on}}{2} = \frac{188 + (-68,5)}{2} = 59,75 MPa$$

$$\sigma'_{ak} = \frac{K_\sigma}{\varepsilon'_\varepsilon \cdot \varepsilon'_\sigma} \cdot \sigma'_a = \frac{1,434}{0,8 \cdot 0,8} \cdot 128,3 = 287,5 MPa$$

$$n_{IV-IV} = \frac{\sigma_{-1p}}{\sigma'_{ak} + \alpha_\sigma \cdot \sigma'_m} = \frac{700}{287,5 + 0,3 \cdot 59,75} = 2,29$$

10.3. Lower head of the connecting rod

The calculation of the lower head of the rod is reduced to the essentials of bending stresses in the section III – III, where acts force of inertia, that maximum value will be at the beginning of filling.

$$P_{j,oz} = -10^{-6} R \cdot \omega_{nx, \max}^2 \cdot [(m_{\bar{o}} + m_{M\bar{o}})(1 + \lambda) + (m_{MK} - m_K)] MN$$

where:

$m_{\bar{o}, ep} = 0,703 kg$ - mass of the piston group;

$m_{M\bar{o}} = 0,165 kg$ - the part of the mass of the rod aligned to the piston;

$m_{MK} = 0,496 kg$ - the part of the mass aligned to the crank;

$m_K = 0,136 kg$ - the mass of the lower head of the rod

$m_M = 0,661 kg$ - the mass of the connecting rod

$$P_{j,oz} = 10^{-6} \cdot 0,032 \cdot 628^2 \cdot [(0,703 + 0,165) \cdot (1 + 0,23) + (0,496 - 0,136)] = 0,0159 MN$$

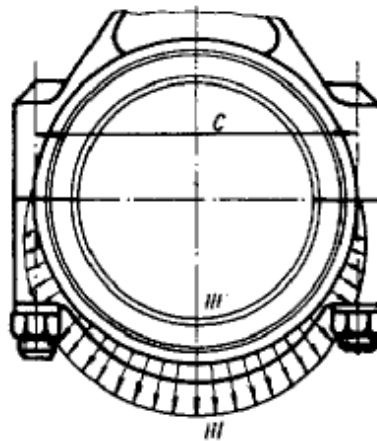

Computational scheme of the lower head of the rod

The tension in the section III – III can be determined by:

$$\sigma_{oz} = P_{j,oz} \cdot \left[\frac{0,023 \cdot C}{\left(1 + \frac{J_n}{J}\right) \cdot W} + \frac{0,4}{F + F_n} \right], MPa$$

where:

$C = 0,086m$ - length between the bolts;

$J = 1,105 \cdot 10^{-8} m^4$ - moment of inertia of the cross section of the lid;

$J_n = 0,0035 \cdot 10^{-8} m^4$ - moment of inertia of the cross section of the bearing shell;

$W = 1,8 \cdot 10^{-6} m^3$ - bending moment of resistance in section III – III;

$F = 4,59 \cdot 10^{-4} m^2$ - cross section area of the lid;

$F_n = 0,69 \cdot 10^{-4} m^2$ - cross section area of the bearing shell;

$$\sigma_{oz} = 0,0159 \cdot \left[\frac{0,023 \cdot 0,086}{\left(1 + \frac{0,0035 \cdot 10^{-8}}{1,105 \cdot 10^{-8}}\right) \cdot 1,8 \cdot 10^{-6}} + \frac{0,4}{4,59 \cdot 10^{-4} + 0,69 \cdot 10^{-4}} \right] = 56,25 MPa < \sigma_{oz}^{don} = 100 MPa$$

Transverse deflection δ of the lower head is:

$$\delta = \frac{0,0024 \cdot P_{j,oz} \cdot C^3}{E \cdot (J + J_l)} = \frac{0,0024 \cdot 0,0159 \cdot 0,086^3}{2,2 \cdot 10^5 \cdot (1,105 \cdot 10^{-8} + 0,0035 \cdot 10^{-8})} = 0,0000189m$$

10.4. Connecting rod pins

In four-stroke engine connecting rod bolts are loaded strength by pre-tightening force P_{np} and the inertia force $P_{j,oz}$.

$$P_{np} = (2 \div 3) \cdot \frac{P_{j,oz}}{i_{\sigma}} = 2 \cdot \frac{0,0303}{2} = 0,0159MN$$

$i_{\sigma} = 2$ - number of connecting rod bolts;

The total tensile force acting on one pin will be:

$$P_{\sigma,on} = P_{np} + \chi \cdot \frac{P_{j,oz}}{i_{\sigma}} = 0,0159 + 0,15 \cdot \frac{0,0159}{2} = 0,0170MN$$

$\chi = 0,15$ – is the coefficient of basic load of bolting;

The maximum and minimum tensile stresses in the bolt are given by:

$$\sigma_{on,max} = \frac{P_{\sigma,on}}{f_{\sigma}} = \frac{0,0170}{0,502 \cdot 10^{-4}} = 338,6MPa$$

$$\sigma_{on,min} = \frac{P_{np}}{f} = \frac{0,0159}{0,480 \cdot 10^{-4}} = 331,2MPa$$

11. Calculation of the crankshaft mechanism

11.1. Dimensions

Crankshaft of the engine is subjected to the action of gas forces, inertial forces and moments, which are periodical functional angle of the knee. These forces and moments induced torsion stress, bending, tension and compression. Furthermore, periodically changing moments cause twisting and bending vibrations, which create additional tensions.

In designing crankshaft we can use parameters of already existing engines:

Distance between the circles of the main journals

$$l = (1,10 \div 1,25).D \quad l = 100mm$$

Diameter of the main journal

$$d_{ouu} = (0,5 \div 0,8).D \quad d_{ouu} = 47mm$$

Length of the main journal

$$l_{ouu} = (0,5 \div 0,6).d_{ouu} \quad l_{ouu} = 36$$

Diameter of the rod journal

$$d_{muu} = (0,50 \div 0,70).D \quad d_{muu} = 47mm$$

Length of the rod journal

$$l_{muu} = (0,45 \div 0,65).d_{muu} \quad l_{muu} = 32mm$$

Thickness of the crank

$$h = (0,15 \div 0,35).d_{muu} \quad h = 12,5mm$$

Width of the crank

$$b = (1,7 \div 2,9).d_{muu} \quad b = 135,5mm$$

Radius of the rounded

$$r = (0,06 \div 0,10) \cdot d_{mu} \quad r = 5mm,$$

11.2. Calculation of full-supporting crankshaft

Crankshaft is calculated through simultaneous action by the following forces and moments:

a) the total gas and inertial force acting in the plane of the knee-force Z_i and in a plane perpendicular to the plane knee-force T_i , determined by the dynamic calculations;

b) centrifugal forces of the rotating masses;

- the mass m_{MK} of the rod to the crank;

$$P_{R,MK} = 10^{-6} \cdot m_{MK} \cdot R \cdot \omega^2 = 10^{-6} \cdot 0,496 \cdot 0,032 \cdot 628^2 = 0,00625MN$$

- by the mass of the rod journal;

$$P_{R,K} = 10^{-6} \cdot m_K \cdot R \cdot \omega^2 = 10^{-6} \cdot 0,426 \cdot 0,032 \cdot 628^2 = 0,00537MN$$

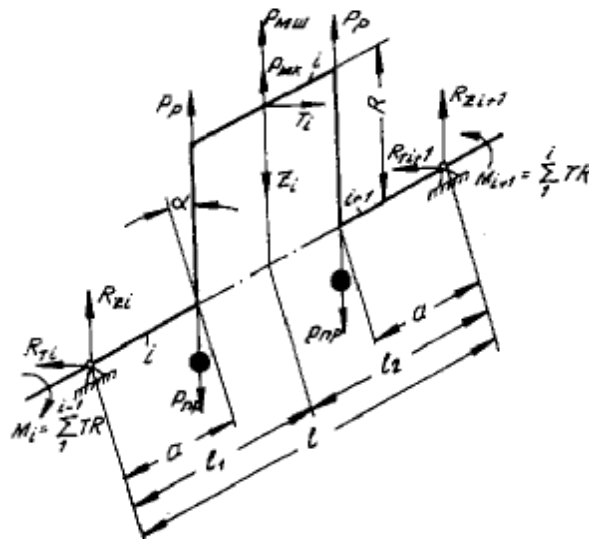

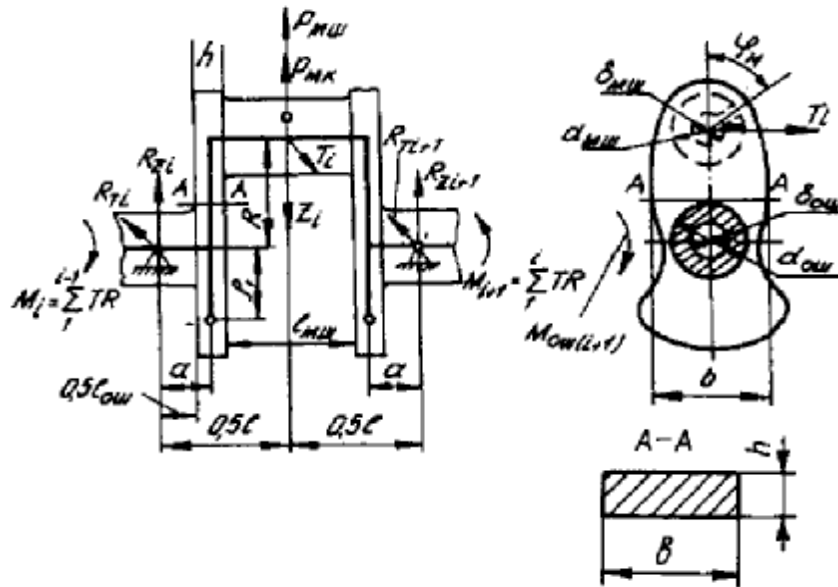

Computational scheme of full-supporting crankshaft

c) the reactions in the plane of the crank;

- o symmetrical knee, when $l_1 = l_2$

$$R_{z_i} = R_{z_{i+1}} = \frac{Z_i}{2} - \frac{1}{2} \cdot (P_{MK} + P_{MU} - 2P_{np}), MN$$

d) the reactions in a plane perpendicular to the plane of the crank for a symmetrically knee;

$$R_{T_i} = R_{T_{i+1}} = \frac{1}{2} T_i, MN$$

e) cumulative torque of the preceding cylinders;

$$M_i = \sum_1^{i-1} T_j R, MNm$$

11.3. Calculation of the journals

The major journals have small length, and for this reason only torsion calculations are needed, without taking into account bending stress. The maximum and minimum value of the torque M_{oui} , transmitted by various journals is determined by successive summation of torque individual cylinders, considering the order of operation of the cylinder and the angle of the crank. In other words, it can be done by making phase shift of the torque of each cylinder to the first cylinder. The maximum and minimum tangential stresses are determined by:

$$\tau_{\max} = \frac{M_{oui, \max}}{W_{\tau ou}}, MPa$$

$$\tau_{\min} = \frac{M_{oui, \min}}{W_{\tau ou}}, MPa$$

where:

$$W_{\tau ou} = \frac{\pi \cdot d_{ou}^3}{16} = \frac{3,14 \cdot 0,063^3}{16} = 49,1 \cdot 10^{-6} m^3 - \text{moment of resistance at torsion}$$

The rod journals are subjected to both torsion of cumulative torque at issue journal M_{mui} and also to bending by the action of bending moment in the plane of the crank M_{Zi} and in the perpendicular plane M_{Ti} .

The safety factor of bending and torsion is determined independently, because the peak of bending moment and torque does not coincide in time. The cumulative torque acting on the connecting rod journal on 'i' crank, is determined by:

$$M_{mui} = M_{oui} + R_{Ti} \cdot R, MNm$$

M_{oui} - the cumulative torque of the prior crank journal;

$R_{Ti} \cdot R$ - moment of torsion;

R_{Ti} - tangential bearing reaction;

$$W_{\tau mu} = \frac{\pi}{16} \cdot d_{mu}^3 \cdot \left[1 - \left(\frac{\delta_{mu}}{d_{mu}} \right)^4 \right]$$

$$W_{\tau mu} = \frac{3,14}{16} \cdot 0,047^3 \cdot \left[1 - \left(\frac{0,005}{0,047} \right)^4 \right] = 17,46 \cdot 10^{-6} m^3$$

In the plane of the crank, the rod journal is bended by the moment:

$$M_{Zi} = (Z_i - B) \cdot \frac{l}{4}, MNm$$

$$B = P_{mk} + P_{mu} - 4 \frac{a}{l} (P_p - P_{np}) - \text{constant centrifugal force};$$

The moment that bends the rod journal in the plane perpendicular to the plane of the crank will be equal to:

$$M_{Ti} = R_{Ti} \cdot \frac{l}{2} = T_i \cdot \frac{l}{4}, MNm$$

The shoulders of the crank are loaded tensile, compression, bending and torsion. At the crank plane, the moment of bending of the shoulder is:

$$M_{zpi} = (Z_i - P_1) \cdot \frac{a}{2}, MNm$$

Compressive and tensile stress is caused by the force:

$$R_{zi} = \frac{Z_i - P_1}{2}, MN$$

Aggregate stresses of bending and compression or tension will be:

$$\sigma_{\Sigma \max} = \frac{M_{zpi \max}}{W_p} + \frac{R_{zi \max}}{f_p}, MPa$$

$$\sigma_{\Sigma \min} = \frac{M_{zpi \min}}{W_p} + \frac{R_{zi \min}}{f_p}, MPa$$

where:

$$W_p = \frac{b \cdot h^2}{6} = \frac{0,136 \cdot 0,0125^2}{6} = 3,52 \cdot 10^{-6} m^3 - \text{moment of resistance of bending}$$

stress of the shoulder;

$$f_p = b \cdot h = 0,136 \cdot 0,0125 = 0,0017 m^2 - \text{section area of the calculation};$$

12. Used Materials

The choice of material for any machine part can be said to depend on the following consideration:

- general function: structural, bearing, sealing, heat-conducting, space-filling;
- environment: loading, temperature and temperature range, exposure to corrosive condition or to abrasive, wear
- life expectancy
- space and weight limitations
- cost of the finished part and of its maintenance and replacement
- special considerations, such as appearance, customer prejudices

Material whose essential function is to carry relatively high stresses will here be classed as structural. The heavily stressed materials include those that carry and transmit the forces and torques developed by cylinder pressure and by the inertia of the moving parts in the power train and valve gear. The success of the structural materials is measured by their resistance to structural failure.

When choosing the material for the parts of the engine, it will be taken those materials that have as high as possible resistance to structural failure due to fatigue.

No	Name	Quantity	Material
1	Block	1	Cast iron
2	Cylinder head	1	Aliminium
3	Intake valve	4	Cast iron
4	Camshaft	1	Steel
5	Spring	8	Steel
6	Exhaust valve	4	Cast iron
7	Piston	4	Aliminium
8	Piston ring	12	Aliminium
9	Piston pin	4	Steel
10	Connecting rod	4	Steel
11	Crankshaft	1	Steel
12	Crankcase	1	Cast iron
13	Gear	4	Steel

13. Conclusion

Internal Combustion engine is one of the most important inventions of the last century. It has been developed in the late 1800s and from there on it has had a significant impact on our society. It has been and will remain for foreseeable future a vital and active area of engineer research.

The aim of this project is to design a four-cylinder internal combustion engine taking into consideration all necessary calculations concerning its basic components. In addition the most proper materials which have to be used have been determined. It has been taken into consideration that the chosen materials must resist on the maximum forces, moments and stresses that occur when the engine is operating. Another goal is to make drawings on CATIA that clearly display the engine structure, connection and location of all parts. And last but not least, to make a simulation and animation of the design engine.

The project begins with short description of the history of engines and how they have developed through the years, because despite of the fact that everyday new and new engines are invented, the main components piston, block, crankshaft, valves and connecting rod have remained basically unchanged. Next to that, the project continues with an explanation of the functions of these parts and the used materials for their production. The next point of consideration is the different types of engines and what their major differences are. Next step of the assignment is kinematics of the engine - determination of piston motion, acceleration and velocity and creating graphs, which show the changes of values depending on the angle between crank and connecting rod. After that gas and inertia forces acting on the connecting rod are determined. Another very important step, achieved in the project is determining equilibrium of the engine. This is essential because if the engine is not in equilibrium condition, it will cause vibration and noise.

Next step made is the calculation of tensile stress and temperature of the cylinder. Another thing that is taken into consideration is the forces acting on strength stud bolts. This is important because strength stud bolts provide density between the cylinder and cylinder head at all mode of operation. The project continues with

calculation of piston group. These calculations are made very precisely, because the piston is the main reciprocating part of an engine and its movement creates an imbalance. To transmit the energy of the piston to the crank, the piston is connected to a connecting rod. Calculation of the connecting rod is of vital importance as it should be done very precisely because when the engine is running the rod is under varying in size and direction gas and inertia forces. For this reason it has been made by stainless steel with high resistance to fatigue. Next step that is taken is calculation of crankshaft mechanism, considering that it is subject to the action of gas forces, inertia forces and moments which are periodical functional angle of knee. In designing the crankshaft, parameters of already existing engines are being used.

After making all mentioned calculation the necessary part dimensions are achieved and the project continues with drawings on CATIA. First of all, 3D drawings of all calculate parts have been made. In addition 2D drawings based on 3D are made. After that ready 3D parts are connected in a product. Having a whole product is just the beginning of the simulation. One of the most difficult things in the project is to make necessary joints in order to have 0 degree of freedom. Achieving 0 degree of freedom means that the mechanism can be simulated.

Having calculated all forces, moments and stresses in an allowable range and animation of operating engine, the main design question have been answered and the objectives of the project achieved.

14. References

Colin R. Ferguson (1986), "Internal Combustion Engine Applied Thermosciences"

John B. Heywood (1988), "Internal Combustion Engine Fundamentals"

Richard Stone (1999), "Introduction to Internal Combustion Engines" (3rd edition)

Charles Fayette Taylor (1985), "The Internal Combustion Engine in the Theory and Practice, Volume 1"

Charles Fayette Taylor (1985), "The Internal-Combustion Engine in the Theory and Practice, Volume 2"

J. H. Weaving (1990), "Internal Combustion Engineering"

Dimitrov L. (2001), "Principle of Mechanical Engineering Design"

Rowland S. Benson (1979), "Internal Combustion Engines, Volume 2"

Ricardo (1933), "The High-Speed Internal Combustion Engine"

Lanchester (1914), "Engine Balancing"

Root (1932), "Dynamics of Engine and Shaft"

McVey (1955), "Materials in Engine Design"

SAE (1957) SP-148 "Crankshaft and rods, bearings, pistons and piston rings"

Holcomb (1955), "Piston Design"

Timoshenko (1947), "Strength of Materials"

Taylor (1933), "New data on Bending Moments in the Master Connecting-Rod"

Bauer (1960), "Engine Blocks and their components"

Black (1956), "Fundamentals of Gear Design and Manufacturing"

15. Drawings

CATIA V5

CATIA (Computer Aided Three-Dimensional Interactive Application) is a multi-platform CAD/CAM/CAE commercial software suite developed by French Dassault Company and marked worldwide by IBM.

CATIA V5 is applied in a wide variety of industries such as aerospace, automotive, industrial machinery, electronics, shipbuilding, plant design and customer goods including design things as clothing and jewelry. Some top names of companies using the software are Toyota, Ford, Goodyear, Boeing, Porsche and many others.

CATIA is the only solution capable of addressing the complete product development process, from product concept specifications through product-in-service to a fully integrated and associative manner.

I have chosen CATIA to design my final project, because it is used in every corner of the globe and only by mastering the software will give me the opportunity to succeed, no matter which career path I would take.

16. Drawings 3D

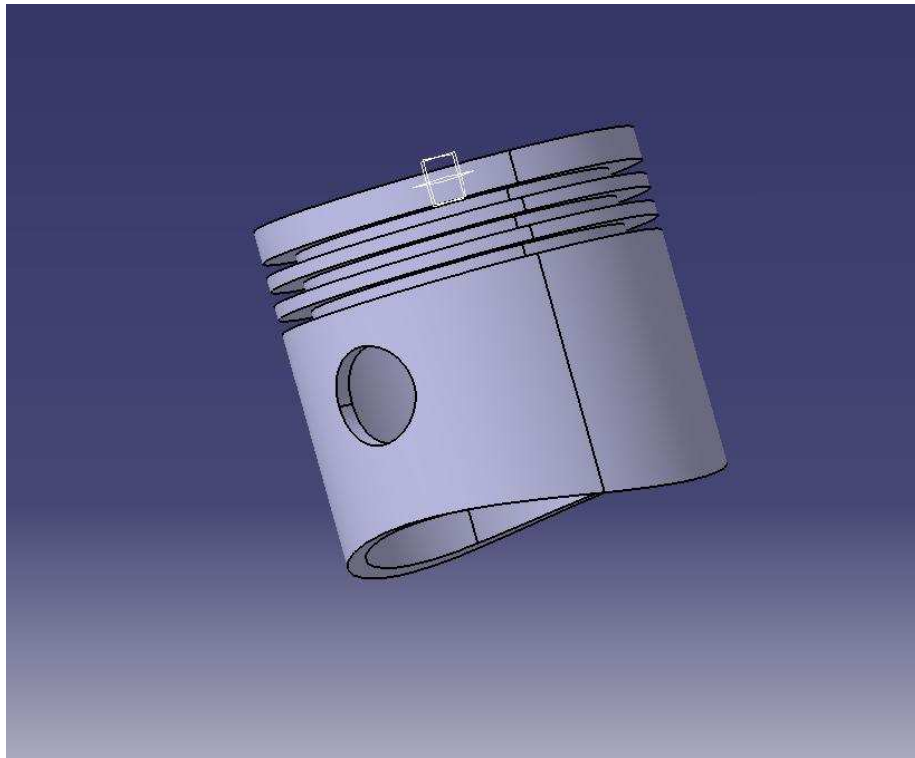

Piston

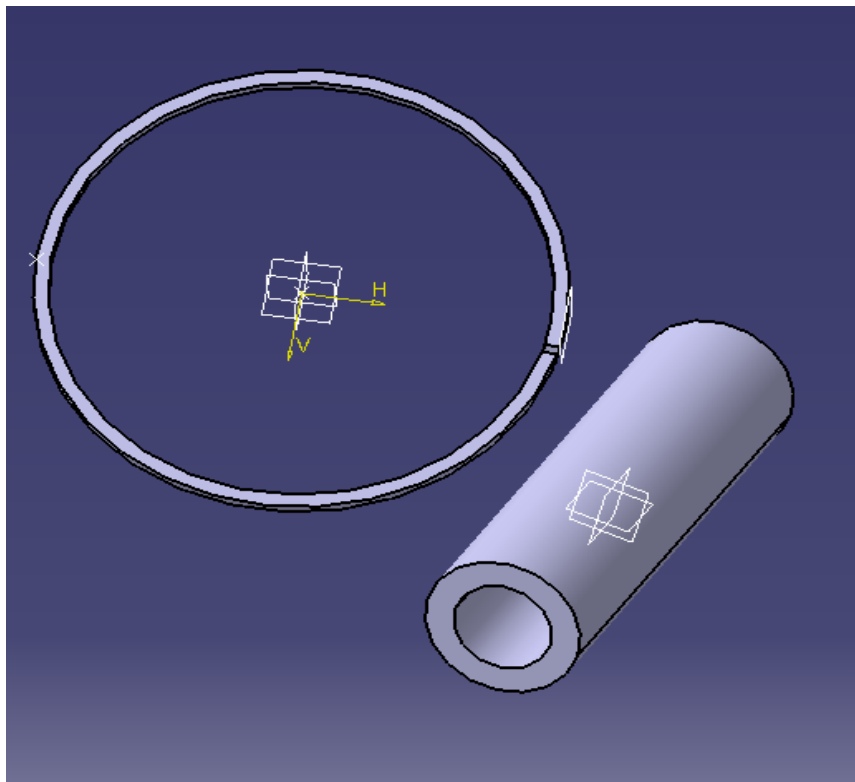

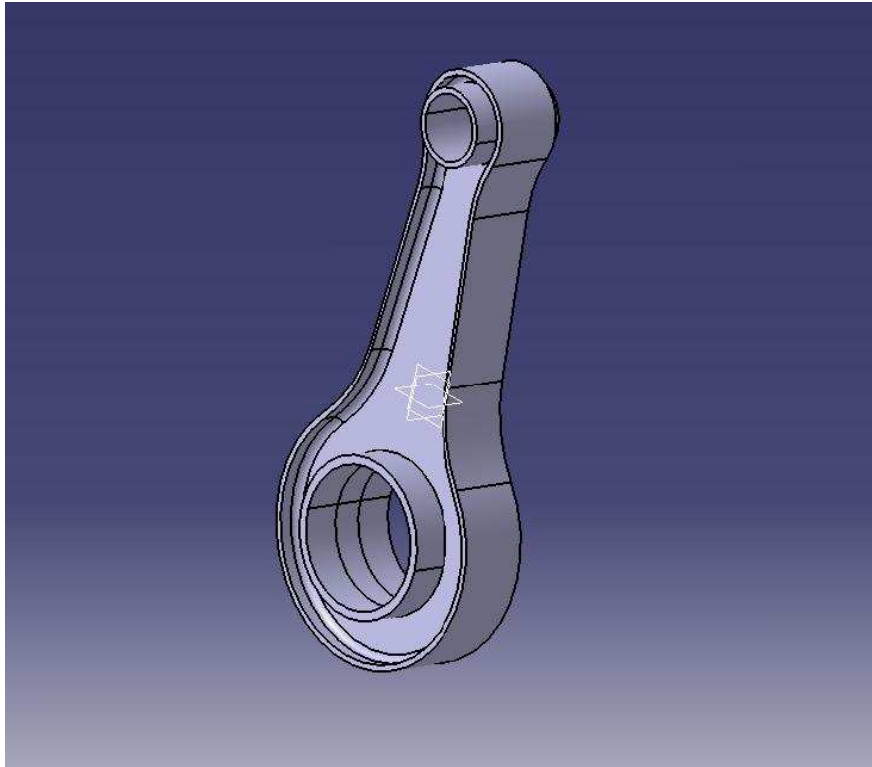

Connecting rod

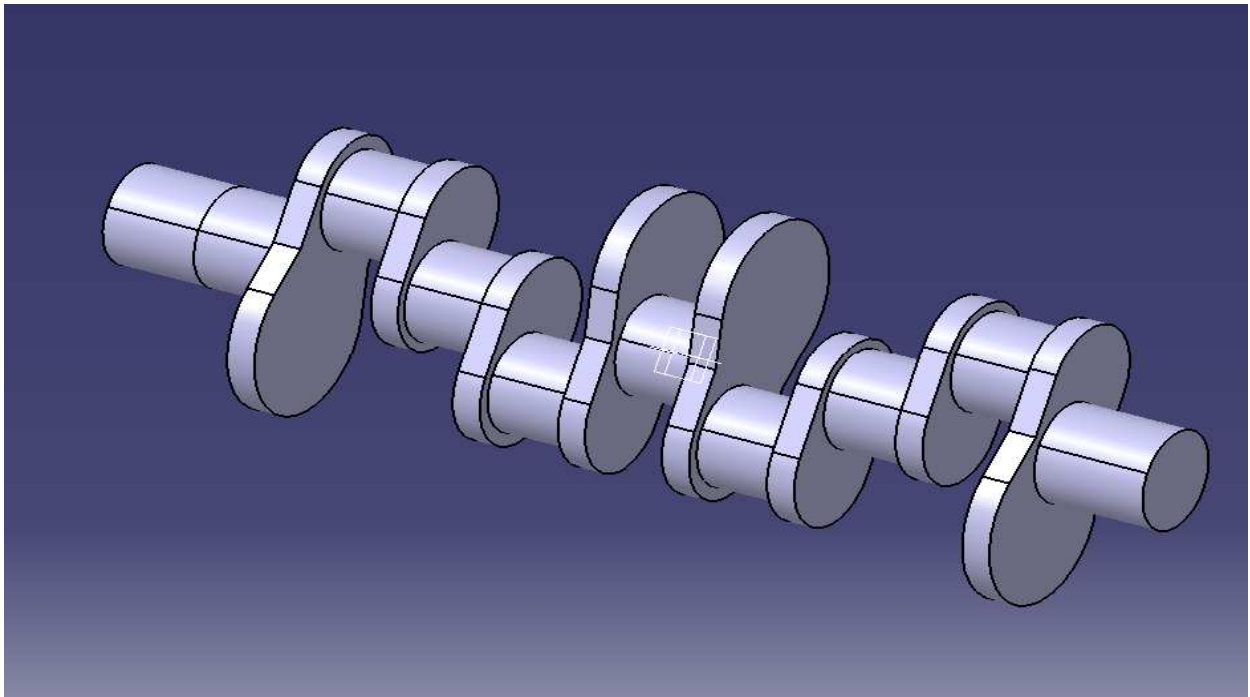

Crankshaft

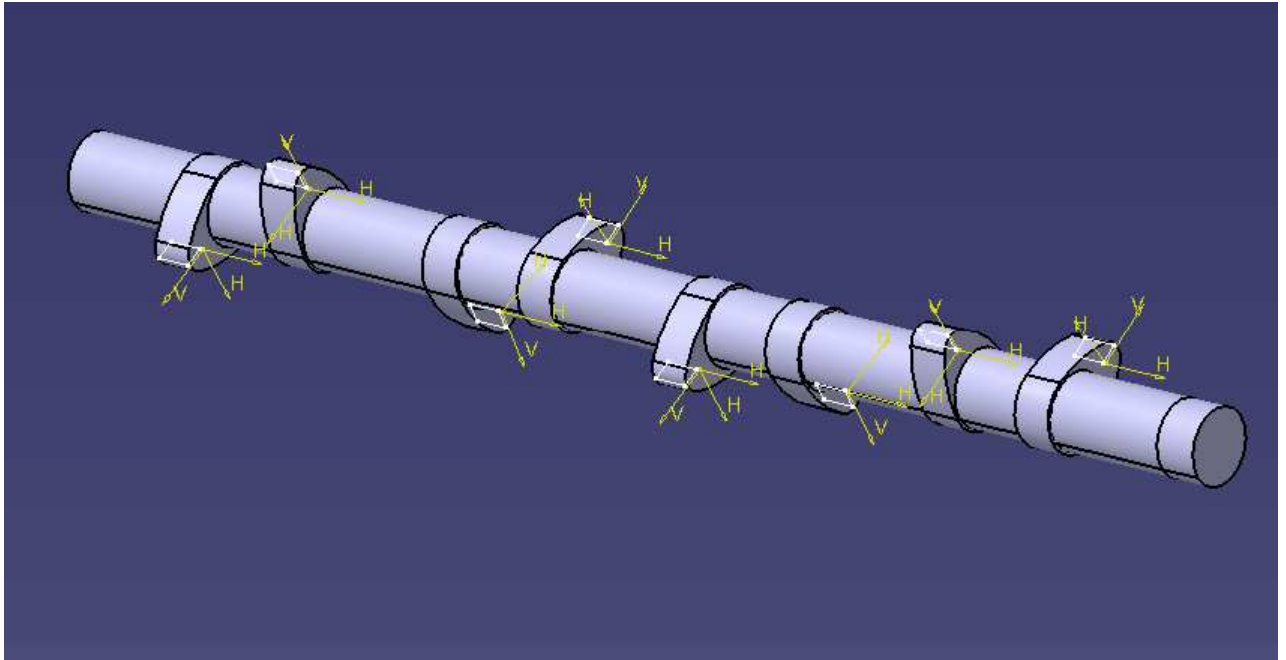

Camshaft

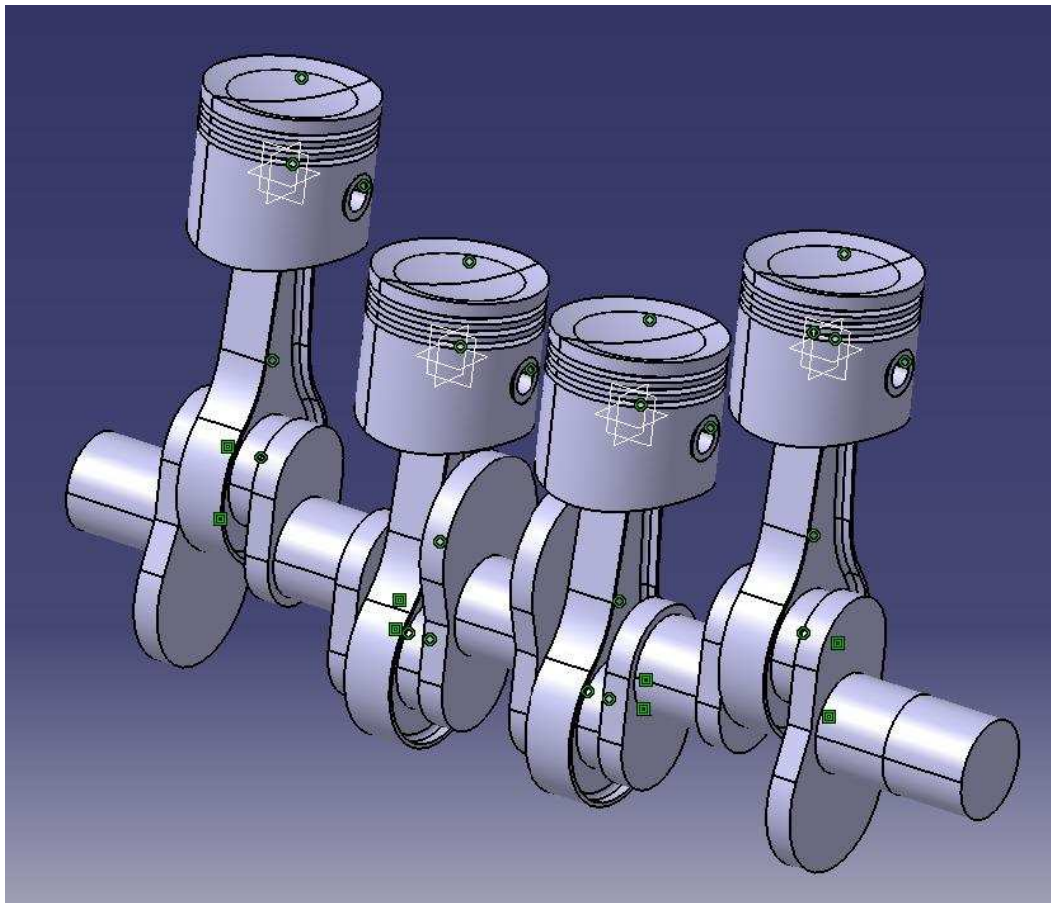

Mechanism 1

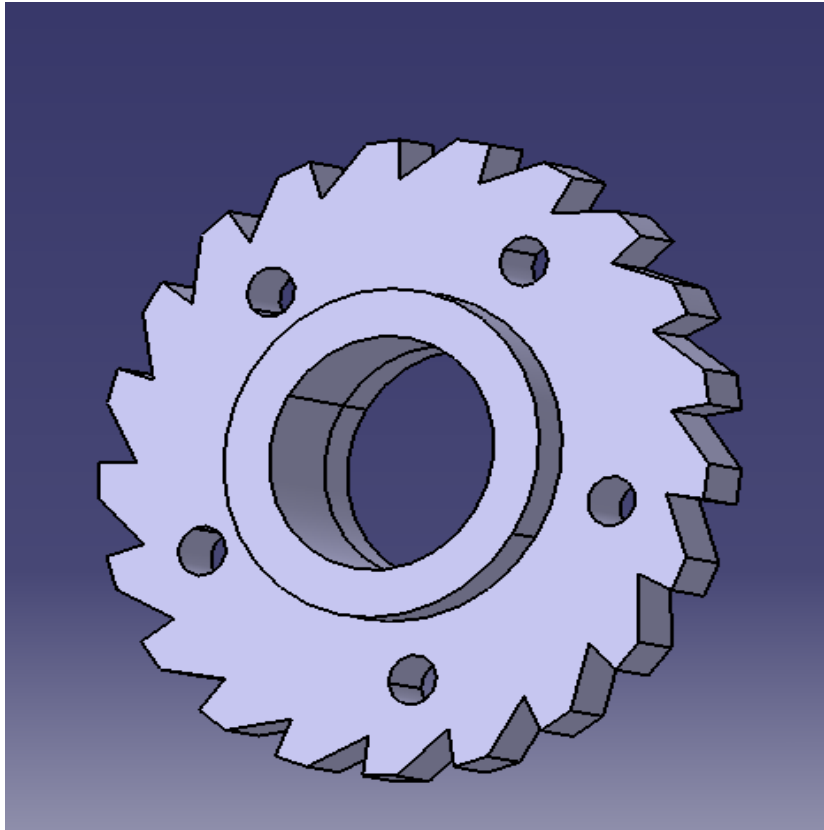

Crankshaft gear

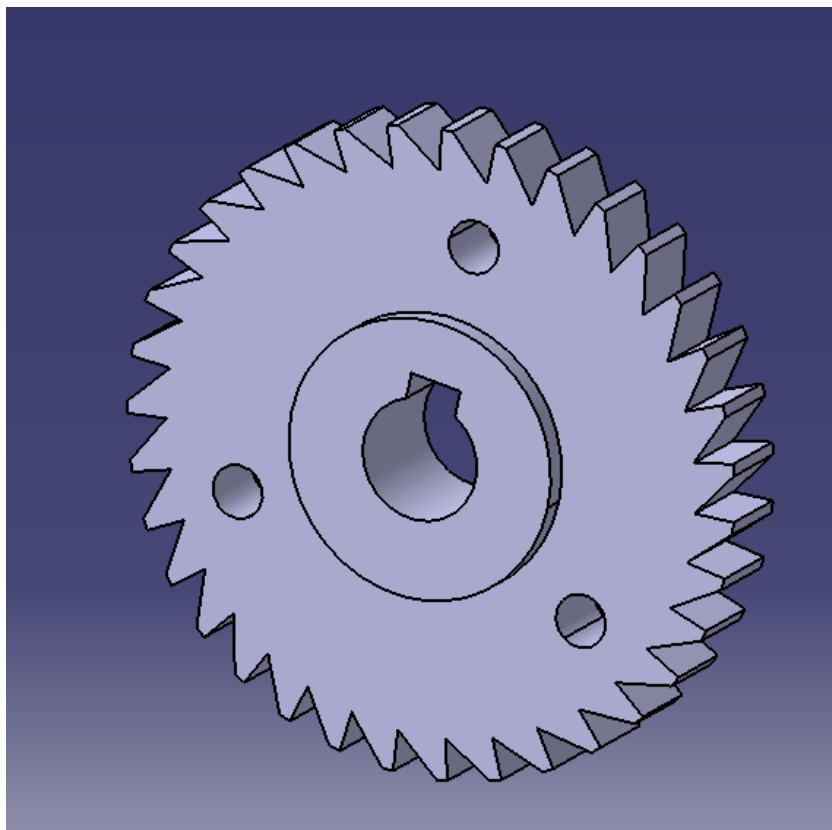

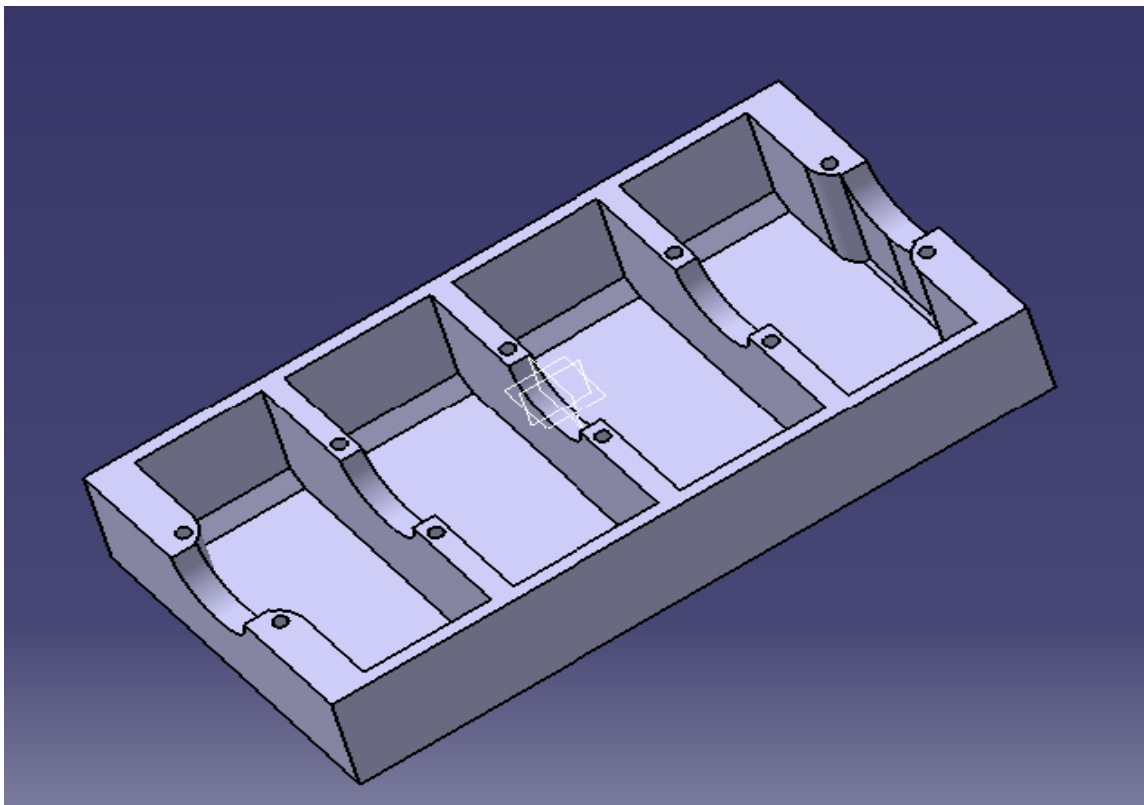
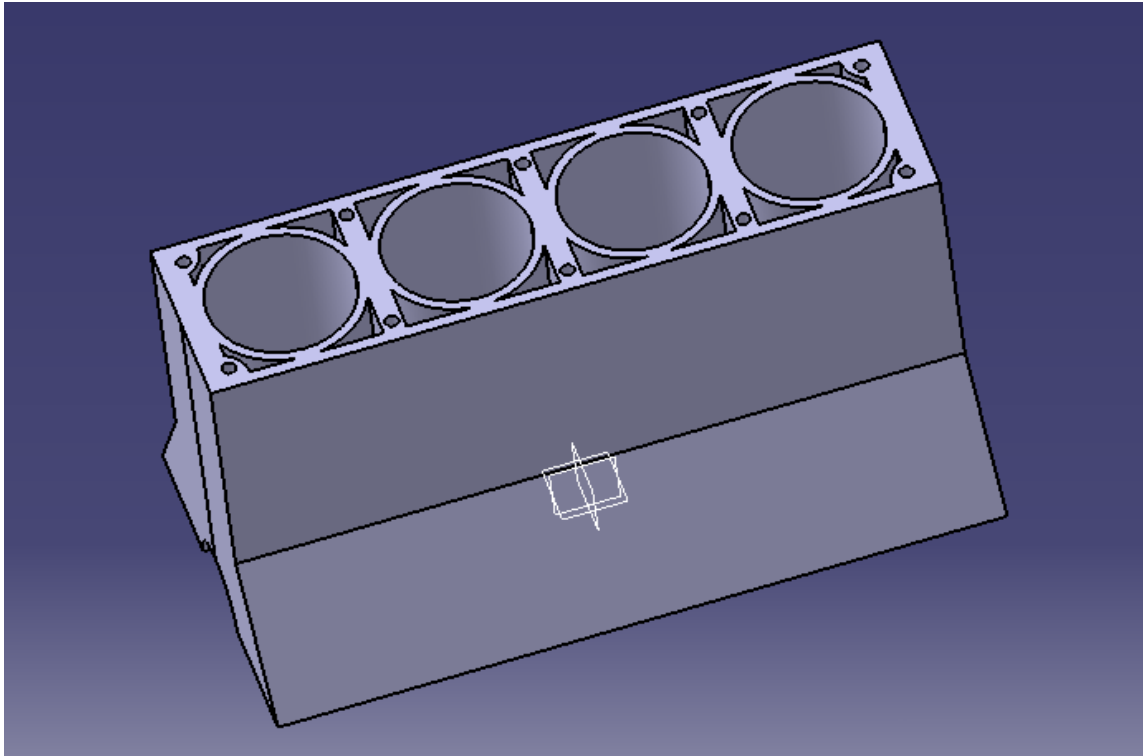

Crankcase

